

AquaA



Water Purification System

Instructions for Use

Software version: 4.40
Edition: 06B-2021
Date of issue: 2022-02
Part no.: F40019672



**FRESENIUS
MEDICAL CARE**

Table of contents

1 Index

2 Important information

2.1	How to use the Instructions for Use	14
2.2	Significance of warnings	16
2.3	Significance of notes	16
2.4	Significance of tips	16
2.5	Brief description	17
2.5.1	Indications for Use	17
2.6	Intended purpose and related definitions	18
2.6.1	Intended purpose	18
2.6.2	Medical indication	18
2.6.3	Intended patient population	18
2.6.4	Intended user group and intended environment	18
2.7	Side effects	18
2.8	Contraindications	19
2.9	Residual risks	20
2.10	Interaction with other systems	21
2.10.1	Intended combined use	21
2.11	Restrictions	21
2.12	Considerations for working on the device	21
2.13	Expected service life	22
2.14	Duties of the responsible organization	22
2.14.1	Further aspects of the responsible organization	22
2.15	Operator responsibility	24
2.15.1	When entering parameters, the following must be observed	24
2.16	Disclaimer of liability	25
2.17	Technical documentation	25
2.18	Warnings	25
2.18.1	Basic warnings	26
2.18.2	Warnings related to hygiene and biology	28
2.18.3	Electrical warnings	30
2.19	Patents	30
2.20	Addresses	31

3 Design

3.1	Views	33
3.1.1	Complete device.....	33
3.1.2	Front view/rear view.....	34
3.1.3	Side view.....	35
3.2	Controls and indicators	36
3.3	User interface	37
3.3.1	Display/touch screen.....	39

4 Operation

4.1	Turning the device on/off	41
4.1.1	Turning the device on.....	41
4.1.2	Turning the device off.....	42
4.2	Operating states, sub-operating modes, access permissions	43
4.3	Device status STANDBY	44
4.3.1	Booting the system.....	44
4.4	STANDBY operating state	45
4.4.1	STANDBY–Active	45
4.4.2	STANDBY–Warning	46
4.4.3	STANDBY–P storage (permeate or dialysis water storage).....	46
4.4.4	STANDBY–Permeate stop	46
4.4.5	STANDBY–External locking	46
4.5	SUPPLY operating state	48
4.5.1	SUPPLY–Start test	49
4.5.2	SUPPLY–Active	50
4.5.2.1	Yield control.....	50
4.5.2.2	Continuous control.....	50
4.5.2.3	Intermittent control.....	50
4.5.3	SUPPLY–Div. to drain	50
4.5.4	SUPPLY–Permeate stop	51
4.5.5	SUPPLY–Warning	51
4.5.6	SUPPLY–External locking	51
4.5.7	SUPPLY–Fill tank	52
4.5.8	SUPPLY–Changing the Autostop time	53
4.6	RINSE operating state	54
4.6.1	Preparing for RINSE.....	56
4.6.2	RINSE–Active	57
4.6.3	RINSE–Water pretreatment	58
4.7	DISINFECTION operating state	59
4.8	EMERGENCY MODE operating state	60
4.8.1	General information.....	60
4.8.2	Turning AquaA EMERGENCY MODE on.....	62
4.8.3	Turning AquaA EMERGENCY MODE off.....	63
4.8.4	AquaA2 EMERGENCY MODE (option).....	64
4.8.5	Turning AquaA2 EMERGENCY MODE on.....	65
4.8.6	Turning AquaA2 EMERGENCY MODE off.....	66
4.8.7	AquaUF EMERGENCY MODE (option).....	67

4.9	FAILURE	68
4.10	STATUS–Menu	69
4.10.1	STATUS–Messages	71
4.10.2	STATUS–Report	72
	4.10.2.1 Daily report AquaA	72
	4.10.2.2 Daily report AquaA2	73
4.10.3	STATUS–Start/Stop	76
	4.10.3.1 Switching program–Supply	76
	4.10.3.2 Switching program–Rinse	77
	4.10.3.3 Switching program–Heat disinfection	79
4.10.4	STATUS–System information	80
	4.10.4.1 System information–device configuration	80
	4.10.4.3 STATUS System information–AquaA2	81
	4.10.4.4 STATUS System information–AquaHT	82
4.10.5	STATUS–Operating data	83
	4.10.5.1 STATUS–Operating data–AquaA	83
	4.10.5.2 STATUS–Operating data–AquaA2	87
	4.10.5.3 STATUS–Operating data–AquaHT	90
4.11	SETUP/SERVICE Menu	92
4.11.1	System menu	93
4.11.2	General information on entering the password	93
4.11.3	SYSTEM –Settings	95
	4.11.3.1 SETTINGS–Report (password-protected)	96
	4.11.3.2 SETTINGS–Switching program (password-protected)	96
	4.11.3.3 Programming the switching programs	97
	4.11.3.4 SETTINGS–Cleaning (password-protected)	98
	4.11.3.5 SETTINGS–Time/Date	102
	4.11.3.6 SETTINGS–Language	103
	4.11.3.7 SETTINGS–Display contrast (password-protected)	104
4.12	SYSTEM–Service (only with password)	104
4.12.1	Access with password	104
4.13	Change password	105

5 Alarms

5.1	Messages	109
5.1.1	Alarm message types	109
5.2	Contact details for the service department	110
5.3	Alarm description	111
5.3.1	Identification of the error code	111
	5.3.1.1 Significance of a fault, failure	111
	5.3.1.2 Significance of a warning, warning condition	111
5.4	Error category 01–system and hardware problems	112
5.5	Error category 02–violation of alarm limits	114
5.6	Error category 03–start condition not fulfilled	119
5.7	Error category 04–Start test and test routines	121
5.8	Alarms and information messages–AquaHT (option)	123
5.9	Alarms and information messages–AquaA2 (option)	127

6 Cleaning, disinfection, preservation

6.1	Generally applicable regulations for cleaning, disinfection and preservation	131
6.1.1	General information	131
6.1.2	Reasons for disinfecting the device	132
6.1.3	Requirements for the clinic technician (Clinic Technician training).....	132
6.2	Precautions	133
6.2.1	Patient safety	133
6.2.2	Operator safety	134
6.3	Disinfection	135
6.3.1	General notes	135
6.3.2	Disinfecting the system	135
6.4	Preservation	136
6.5	Surface cleaning	136
6.5.1	General information	136
6.6	Surface disinfection	137
6.6.1	General information	137
6.6.2	Surface disinfectant	137

7 Functional description

7.1	Description of the procedure	139
7.1.1	Functions	139
7.1.2	RingBase	139
7.1.3	RingUnit (option).....	140
7.1.4	Flow diagrams	140

8 Consumables, accessories, additional equipment

8.1	Consumables	142
8.2	Additional equipment/options	143
8.3	Modules/Accessories	144

9 Installation

9.1	Installation requirements	145
9.1.1	General information	145
9.1.2	Environment.....	145
9.1.3	Power supply system (electrical)	146
9.2	Operational Qualification	147
9.2.1	To be observed before Operational Qualification	147
9.3	System-specific requirements	148
9.3.1	General information	148
9.3.2	Hydraulic connection requirements	148
9.3.3	Requirements for electric connections.....	148

9.4	Operational Qualification procedure	149
9.4.1	After Operational Qualification.....	149
9.5	Decommissioning / shutdown / operational requalification	150
9.5.1	Decommissioning	150
9.5.2	Shutdown.....	150
9.5.3	Operational requalification.....	150

10 Transport/storage

10.1	Transport and storage conditions	153
10.2	Transport	154
10.3	Environmental compatibility/disposal	154

11 Technical Safety Checks and maintenance

11.1	Important information for the procedure	155
11.2	Maintenance procedures	155

12 Specifications

12.1	Dimensions and weight	157
12.1.1	Device data.....	157
12.2	Identification label (device identification)	158
12.3	Electrical safety	159
12.4	Electrical supply	160
12.5	Fuses	160
12.6	Information on electromagnetic compatibility (IEC 60601-1-2)	162
12.6.1	Essential performance.....	162
12.6.2	Minimum distances between radiation source and medical electrical equipment	162
12.6.3	Guidance and manufacturer's declaration on EMC	164
12.7	Operating conditions	167
12.8	Transport/storage	169
12.9	External connection options	169
12.10	Materials used	172
12.10.1	Device materials.....	172
12.11	Specifications–AquaA2	173
12.12	Specifications–AquaHT	177
12.13	Specifications–AquaUF	181

13 Definitions

13.1	Definitions and terms	183
13.2	Abbreviations	183
13.3	Symbols	184
13.4	Certificates	185

14 Options

14.1	AquaA2	187
14.1.1	Preface	187
14.1.2	Functional description– AquaA2	188
14.1.3	Design– AquaA2	189
14.1.4	Operating modes– AquaA2	190
14.1.5	STANDBY device status– AquaA2	190
14.1.6	SUPPLY mode– AquaA2	190
14.1.7	RINSE mode– AquaA2	190
14.1.8	DISINFECTION mode– AquaA2	190
14.1.9	EMERGENCY MODE mode– AquaA2	190
14.1.10	STATUS Start/Stop– AquaA2	190
14.1.11	Cleaning, disinfection, preservation– AquaA2	191
14.1.12	Consumables, accessories, additional accessories– AquaA2	191
14.2	AquaHT	192
14.2.1	Preface	192
14.2.2	Functional description– AquaHT	193
14.2.3	Design– AquaHT	194
14.2.4	HEAT DISINFECTION mode– AquaHT	196
14.2.5	SUPPLY mode– AquaHT	209
14.2.6	RINSE mode– AquaHT	209
14.2.7	DISINFECTION mode– AquaHT	209
14.2.8	Cleaning, disinfection, preservation– AquaHT	210
14.2.9	Functional description– AquaHT	210
14.2.10	Consumables, accessories, additional accessories– AquaHT	211
14.3	Ultrafilter AquaUF	212
14.3.1	Functional description– AquaUF	212
14.3.2	Design– AquaUF	213
14.3.3	SUPPLY mode– AquaUF	214
14.3.4	RINSE mode– AquaUF	214
14.3.5	DISINFECTION mode– AquaUF	214
14.3.6	HEAT DISINFECTION mode– AquaUF	214
14.3.7	Cleaning, disinfection, preservation– AquaUF	214
14.4	TSDiag+–diagnostics tool	215
14.4.1	Starting the TSDiag+	215

15 Appendix

15.1	AquaA Medical Device Register	219
15.1.1	Responsible organization and identification	219
15.1.2	Contents of the AquaA Medical Device Register	221

15.2	AquaA–Training Record	223
15.3	Operational data acquisition	229
15.3.1	Manual operational data acquisition report.....	229
15.3.2	Manual operational data acquisition report.....	231
15.4	Quality of dialysis water	232
15.5	Collecting a sample at the AquaA for microbiological analysis	234
15.5.1	Preparation	234
15.5.2	Accessories, equipment	234
15.5.3	Collecting a sample on the AquaA	234
15.6	Collecting a sample for microbiological analysis	237
15.6.1	Preparation	237
15.6.2	Accessories, equipment	237
15.6.3	Collecting a sample on the MSC	238
15.7	Collecting a sample for chemical analysis	239
15.7.1	Preparation	239
15.7.2	Accessories, equipment	239
15.7.3	Collecting a sample for chemical analysis.....	239

1 Index

A

Abbreviations 183
 Accessories 143
 Additional equipment/options 143
 Alarms 109
 Appendix 187, 219

B

Booting the system 44
 Brief description 17

C

Certificates 185
 Change password 105
 Changes 15
 Chemical quality of dialysis water 233
 Cleaning / disinfection 131
 Collecting a sample on the AquaA 234
 Collecting a sample on the MSC 238
 Considerations for working on the device 21
 Consumables 142
 Contraindications 19
 Controls and indicators 36

D

Decommissioning 150
 Definitions and terms 183
 Description of the procedure 139
 Device data 157, 173, 177
 Device status STANDBY 44
 Dimensions and weight 157
 Disclaimer of liability 25
 Disinfection 135
 DISINFECTION operating state 59
 Display / touchscreen 39
 Duties of the responsible organization 22

E

Electrical safety 159
 Electrical supply 160
 Electromagnetic emissions 164
 Electromagnetic immunity 165
 EMERGENCY MODE operating state 60
 Environmental compatibility/disposal 154
 Error category 01 112
 Error category 02 114
 Error category 03 119
 Error category 04 121, 123, 127
 Error code 111

F

Flow diagrams 140
 Front view / rear view 34
 Functional description / definitions 139, 183
 Fuses 160

G

Guidelines and manufacturer's declaration on EMC 164

I

Identification label 158
 Important information 13
 Information on electromagnetic compatibility 162
 Installation 145
 Intended patient population 18
 Intended purpose and related definition 18
 Interaction with other systems 21

M

Microbiological quality of fluids for hemodialysis 232
 Modules/Accessories 144

N

Notes, significance 16

O

Operating conditions 167
 Operation 41
 Operational qualification 183
 Operational requalification 150
 Operator responsibility 24
 Operator safety 134

P

Patents 30
 Patient safety 133
 Precautions 133
 Preservation 136

Q

Quality of dialysis water 232

R

Requirements for electric connections 148
 Residual risks 20
 RingBase 139
 RingUnits 140
 RINSE operating state 54

S

Service International 31
 Service life 22
 Shutdown 150
 Side effects 18
 Side view 35
 Specifications 157
 STANDBY operating state 45
 SUPPLY operating state 48
 Surface cleaning 136
 Surface disinfection 135, 137
 Symbols 184

SYSTEM settings 95
SYSTEM–Service 104
System-specific requirements 148

T

Target group 18
Technical documentation 25
Technical Safety Checks and maintenance 155
Tips, significance 16
Transport 154
Transport / storage 153
Transport/storage 153
Turning the device On 41, 42

U

User interface 37

W

Warnings 25
Warnings, basic 26
Warnings, electrical 30
Warnings, hygiene and biology 28
Warnings, significance 16

2 Important information

- Notation for main device and options of the AquaA



Note

Notation for main device and options of the AquaA

The following document describes the **AquaA** reverse osmosis system as well as the available options for the main device of the **AquaA**.

Notation of the main device:

- The main device of the **AquaA** reverse osmosis system is named **AquaA**.

The following options are separate devices and are named as follows:

- **AquaA2**,
- **AquaHT**,
- **AquaUF**,

Examples of system combinations consisting of the main device and options are as follows:

- **AquaA** (main device) + **AquaA2** (option, second stage):
- **AquaA-A2** (main device with second stage)

More examples for combinations:

- **AquaA-A2-HT** (two-stage reverse osmosis system with heat disinfection tank option)
 -
-

2.1 How to use the Instructions for Use

Device type	In this document, the device type AquaA is referred to as “device”.										
Identification	<p>The document can be identified by the following information on the title page and on the labels, if any:</p> <ul style="list-style-type: none"> – Device software version – Document edition – Issue date for the document – Document part number 										
Footer	<p>The footer contains the following information:</p> <ul style="list-style-type: none"> – Company name – Device type – The abbreviation for the document type and the international abbreviation for the document language, e.g., IFU-EN-US means Instructions for Use in English for US-devices. – Edition information, e.g., 4A-2013 means edition 4A from the year 2013 – The page identification, e.g., 1-3 refers to chapter 1, page 3. 										
Organization of the chapters	<p>To facilitate the use of documents from Fresenius Medical Care, the organization of the chapters has been standardized in all manuals. There may therefore be chapters within this document without any content. Chapters without content are identified.</p>										
Forms of notation found in the document	<p>The following forms of notation may be used in the document:</p> <table border="1" style="width: 100%; border-collapse: collapse;"> <thead> <tr style="background-color: #ADD8E6;"> <th style="text-align: left;">Form of notation</th> <th style="text-align: left;">Description</th> </tr> </thead> <tbody> <tr> <td style="vertical-align: top;">Name of key</td> <td>Keys on the device are written in bold. Example: Example key.</td> </tr> <tr> <td style="vertical-align: top;">Message text</td> <td>Device messages are written in bold. Example message: Example message</td> </tr> <tr> <td style="vertical-align: top;">➤ Instruction</td> <td>Instructions are indicated by an arrow ➤. All instructions must be followed. Example: ➤ Carry out instruction.</td> </tr> <tr> <td style="vertical-align: top;">1. Numbered instruction 2. ... 3. ...</td> <td>Long passages containing instructions can be represented by numbers. The actions specified in instructions must be performed. Example: 1. Carry out instruction.</td> </tr> </tbody> </table>	Form of notation	Description	Name of key	Keys on the device are written in bold . Example: Example key.	Message text	Device messages are written in bold . Example message: Example message	➤ Instruction	Instructions are indicated by an arrow ➤. All instructions must be followed. Example: ➤ Carry out instruction.	1. Numbered instruction 2. ... 3. ...	Long passages containing instructions can be represented by numbers. The actions specified in instructions must be performed. Example: 1. Carry out instruction.
Form of notation	Description										
Name of key	Keys on the device are written in bold . Example: Example key.										
Message text	Device messages are written in bold . Example message: Example message										
➤ Instruction	Instructions are indicated by an arrow ➤. All instructions must be followed. Example: ➤ Carry out instruction.										
1. Numbered instruction 2. ... 3. ...	Long passages containing instructions can be represented by numbers. The actions specified in instructions must be performed. Example: 1. Carry out instruction.										
Illustrations	<p>The illustrations used in the documents may differ from the original if this does not have any influence on the function.</p>										
Importance of the instructions	<p>The Instructions for Use are part of the accompanying documents and are an essential part of the device. They include all information necessary for the use of the device.</p>										

The Instructions for Use must be carefully studied before Operational Qualification of the device.

Changes

Changes to documents will be released as new editions or supplements. In general, these instructions are subject to change without notice.

Reproduction

Reproduction, even in part, is only permitted with written approval.

2.2 Significance of warnings

Advises the operator that failure to comply with the measures for avoiding the hazard may result in serious or fatal personal injuries.



Warning

Type and cause of the hazard

Possible consequences if the hazard arises.

➤ Measures for preventing the hazard.

The warnings can deviate from the sample above in the following cases:

- if a warning refers to several hazards.
- if a warning cannot be assigned to a specific hazard.

2.3 Significance of notes



Note

Advises the operator that failure to observe this information can:

- cause damage to the device;
 - result in a specific function not being executed at all or not being executed correctly.
-

2.4 Significance of tips



Tip

Information providing useful tips for easy handling.

2.5 Brief description



The device reflects the latest state of technology. It is equipped with all safety systems required for its function and for patient safety. It complies with the requirements of ANSI/AAMI ES60601-1.

The **AquaA** is a reverse osmosis system which can be extended by the responsible organization with additional components to a complete, double pass system for the production and supply of dialysis water.

The reverse osmosis system produces highly deionized water, also called dialysis water.

If necessary, additional modules can be connected downstream for improved quality. The dialysis water can be used for dialysis treatments or for the production of concentrates.



Caution:

Federal law restricts this device to sale by or on the order of a physician.

2.5.1 Indications for Use

The **AquaA** water purification system is a modular reverse osmosis unit intended for use with hemodialysis systems to remove organic and inorganic substances and microbial contaminants from the water used for treating hemodialysis patients or related therapies. This device is intended to be a component in a complete water purification system and is not a complete water treatment system. The reverse osmosis unit must be preceded by pre-treatment devices and may need to be followed by post-treatment devices as well, to meet current AAMI/ANSI/ISO and Federal (U.S.) standards.

2.6 Intended purpose and related definitions

2.6.1 Intended purpose

Production of dialysis water for dialysis treatments

2.6.2 Medical indication

Renal insufficiency requiring renal replacement therapy, supported by a reverse osmosis system for the treatment of water.

2.6.3 Intended patient population

The **AquaA** has no clinical effect on its own. The device only supplies purified product water as dialysis water, which is required for the production of standard dialysates. There are therefore no restrictions regarding the intended patient population. The intended patient population is defined by the hemodialysis device.

2.6.4 Intended user group and intended environment

The device must only be installed, operated, and used by individuals with the appropriate training, knowledge, and experience, and who are certified to have been trained.

The device must be operated in rooms that are suitable for operating reverse osmosis systems and which are located in professional health care establishments.

2.7 Side effects

As dialysis water has no direct clinical effect, there are no side effects that can be attributed solely to the use of dialysis water. Dialysis water is always used in combination with a hemodialysis treatment. Increased calcium, magnesium, and iron content in dialysis water can cause hard-water syndrome, resulting in nausea, vomiting, weakness, and/or high blood pressure.

The following list contains known side effects related to hemodialysis treatment according to current literature:

- Acute urticaria
- Anxiety
- Impaired quality of life
- Clotting
- Blood loss
- Depressive symptoms
- Dialysis disequilibrium syndrome
- Thirst
- Vomiting
- Fever
- Hemolysis
- Hypotension
- Itching
- Cardiac arrhythmia
- Headache
- Seizures
- Cramps
- Micro air embolisms
- Cardiac tamponade
- Reactions to the dialyzer
- Sleep disturbance
- Pain (chest and back)
- Shivering
- Falls
- Nausea
- Restlessness

2.8 Contraindications

As permeate or dialysis water is never used directly on patients, there are no known contraindications. However, there are certain contraindications when used in the context of hemodialysis treatment:

- Hyperkalemia (only with potassium-containing hemodialysis concentrates)
- Hypokalemia (only with potassium-free hemodialysis concentrates)
- Uncontrollable blood-clotting disorders

Relative contraindications (predictors for poor treatment outcome/treatment decision on an individual basis):

- Hypotensive heart failure
- Malignant disease with poor prognosis
- Severe peripheral arterial disease (no access possible)
- Severe mental illness to the extent that patient is not aware of treatment and cannot comply.

A different method of extracorporeal treatment may be indicated for hemodynamically unstable patients.

2.9 Residual risks

Operating the device	All instructions and operating steps in these Instructions for Use must be carried out completely and conscientiously. The system may only be operated by persons who have received the necessary training.
Use of non-specified disinfectant	Use only the agents described herein as disinfectants. – Minnicare® If other disinfectants are used, the desired disinfection effect and the appropriate safety are no longer ensured.
Microbial contamination of feed water	The feed water must be of drinking water quality (in accordance with local requirements). The Drinking Water Decree stipulates that the water must be free from pathogens. In some countries, it is very difficult to achieve this quality. We recommend that the water therefore be checked continuously.
Checking the water inlet quality	The design of the water treatment system must ensure that the necessary parameters are fulfilled. We recommend that the water inlet quality be checked on a regular basis.
Tests for residual disinfectant (after a disinfection)	Tests for residual disinfectant after a disinfection must be performed conscientiously. Any mistakes present a severe hazard for the patient.
Microbiological monitoring	We strongly recommend that the entire device installation (in particular, the dialysis water and dialysis water ring main) be monitored at regular intervals with microbiological testing, and that appropriate cleaning and disinfection procedures be carried out.
Contraindications	There are no known contraindications. Contraindications may be induced by the downstream form of treatment (hemodialysis).

2.10 Interaction with other systems

2.10.1 Intended combined use

The **AquaA** device can be combined with the following options:

AquaA2	By connecting an AquaA2 , the device is extended into a double pass reverse osmosis system. The product passes through both devices to produce an even purer form of dialysis water. With this option, emergency operation of the system is also possible in the event that one of the two devices should fail.
AquaHT	AquaHT is a module for heat disinfection of the ring main. Using heat disinfections, it is possible to disinfect both the connected ring main as well as any dialysis devices connected to the ring main.
AquaUF	The ultrafilter is used as an optional filter to aid in filtering bacteria and endotoxins. It is installed at the outlet of the AquaA or AquaA2 and ensures an even higher quality of dialysis water. Regardless of which options are connected to the device, the system is operated via the AquaA control.
TSDiag+	Diagnostics tool: The TSDiag+ tool can be used for remote visualization of the AquaA display on a client (Windows notebook or PC with a connection to the network). The AquaA can be accessed within the local clinic network via this client.

2.11 Restrictions

None

2.12 Considerations for working on the device



Warning

Risk of injury to the patient and user caused by improper service work on the device

The device no longer operates properly after service work. The device contains live components, among others.

Operational qualification, expansions, adjustments, calibration, maintenance procedures, modifications or repairs may only be carried out by the manufacturer or manufacturer-authorized persons.

To perform the Technical Safety Checks and the maintenance procedures, contact the local service department.

Use only original spare parts. To identify and order spare parts, test equipment, and tools, always use the electronic spare parts catalog.

Transport and storage (see chapter 10 on page 153)

2.13 Expected service life

The expected service life is 10 years.

2.14 Duties of the responsible organization

The responsible organization must ensure

- compliance with the national or local regulations concerning the installation, operation, use, and maintenance of the device.
- compliance with the accident prevention regulations.
- correct and safe condition of the device.
- making the Instructions for Use available at all times.

2.14.1 Further aspects of the responsible organization

- The device is a system for the production of dialysis water for dialysis treatments which can be extended by the responsible organization with additional components to form a complete water treatment system. The system must be installed in a dry room which is not used for medical procedures. A staff call feature should also be enabled.
- The responsible organization must ensure that the technical design of the system matches the requirements of the other components used to make up the complete system.
- The reverse osmosis system must be easily accessible from all sides. The responsible organization must prepare a plan for emergency operation to supply dialysis devices with dialysis water based on the available system components and must make this plan available to the operators of the system.
- The responsible organization must ensure that its operators have been trained. Operators of the reverse osmosis system and the dialysis devices must have received instructions on how to operate the system.
- The responsible organization should inform the local water supplier of the dialysis operation and insist on prior discussion with regards to water composition, availability, etc. This measure does not relieve the responsible organization of its obligation to regularly check the inlet water composition.

- Bacterial growth in the reverse osmosis system depends on the individual components, and the type and time of use. Bacterial growth in the system must be prevented by continuous operation of the system with a minimum of idle times and by preventive measures such as chemical disinfection or heat disinfection.
- Samples for microbial testing must therefore be collected from the system and from the individual parts of the system in accordance with the applicable regulations. As the complete system consists of a number of smaller systems, the responsible organization is responsible for the complete system.
- The key required to open the door to the control cabinet must not remain on the system and access to the key must be restricted to the certified service technicians.

2.15 Operator responsibility



Warning

Risk of injury from device defects

If the device has the following defects, the indicated measures must be taken:

Device defects:

- Mechanical damage
- Faulty power cable
- Other defects
- Device not responding as expected
- Deterioration of performance

Measures:

- The device must be taken out of service.
 - The responsible organization or the local service must be notified.
-

2.15.1 When entering parameters, the following must be observed

- The parameters entered must be verified by the operator, i.e., the operator must check that the values entered are correct.
- If this check reveals a deviation between the required parameters and the parameters displayed on the device, the setting must be corrected before activating the function.
- The actual values displayed must be compared with the target values specified.
- The device must only be operated under the operating conditions specified by the manufacturer (see chapter 12.7 on page 167).

2.16 Disclaimer of liability



Warning

Risks affecting the proper functioning of the device

The device has been approved for use with certain consumables and accessories. Should the responsible organization wish to use other consumables and accessories than those listed in this chapter, the suitability must be checked beforehand by gathering the appropriate manufacturer information.

The applicable legal regulations must be complied with.

The manufacturer does not assume any responsibility or liability for personal injury or other damage, and the use of non-approved or unsuitable consumables or accessories resulting in damage to the device will void the warranty.



Tip

For further information on the topic of consumables, accessories, additional equipment (see chapter 8 on page 141).

2.17 Technical documentation

Upon request, circuit diagrams, descriptions, and other technical documents are made available by the manufacturer. These are intended to support appropriately trained personnel of the responsible organization in maintaining and repairing the system.

2.18 Warnings

The list of warnings that follows is only an excerpt. Safe use of the device requires knowledge of all warnings contained in these Instructions for Use.

2.18.1 Basic warnings



Note

The **AquaA** may only be operated under the specified operating conditions:

- Appropriate water pretreatment in accordance with the specified inlet requirements is required.
- The control unit must be protected against humidity (splash water, condensation water, etc.) and moisture.
- In the event of a defect of the control unit, the type of problem (effect of the malfunction) should be recorded before dismantling the system. A system that has been dismantled can only be repaired if a detailed description of the problem is available.
- The total output (rated output) of the reverse osmosis system must not be exceeded.
- Appropriate pipe fittings must be provided to ensure that the soft water inlet side is reliably protected against a water inlet pressure of 6 bar.
- Only the membranes installed by the manufacturer may be used. Replacement of membrane units with units not explicitly approved for use by the manufacturer is not permitted.



Warning

Operator restrictions

Access to the **AquaA** reverse osmosis system must be restricted to authorized personnel.



Warning

Preventing leakage damage

The following measures must be implemented to avoid severe damage to buildings:

- The room where the reverse osmosis system is operated must be equipped with a floor drain and have a floor which is resistant to water as well as the cleaning agents and disinfectants used.
 - To prevent damage to buildings outside dialysis hours (unattended times without staff) caused by water leakage, a leakage monitoring system with a shut-off function, such as the **AquaDETECTOR** with leakage sensors, should be installed in every room with user points.
 - If no leakage monitoring system is installed, it is recommended that all supply tubes be disconnected from the ring main outside dialysis hours (unattended times without staff).
-



Note**Responsible organization**

The responsible organization must ensure that the Technical Safety Checks (TSC) are performed.

**Warning****TSC procedure**

The Technical Safety Checks / maintenance procedures (local service department) for this device must be carried out at least once every **24 months**.

The measurements may only be performed by certified service technicians with electrical, system-related, and medical/technical knowledge.

**Note**

The selection of a water treatment system for dialysis is the operator's responsibility. The water produced must be regularly tested.

**Warning****Regular checks**

Damage / injury caused by leaking fluid

- Regular visual inspection and leakage checks of all tubing, connectors, and piping containing fluid of the **AquaA** are required.
 - Tubing must be protected against possible mechanical damage.
-

**Note****Adherence to applicable laws and regulations**

- Observe the applicable local laws and regulations concerning the handling of laboratory equipment and reagents.
-

**Warning****Risk of burning/scalding**

- Do not touch the system components while heat disinfection is in progress.
 - Do not attempt to remove fluids manually while heat disinfection is in progress.
-



Warning

Risk of injury from explosions

- Do not use the device in explosive or flammable atmospheres (e.g., oxygen-enriched atmospheres).
-



Warning

Damage to buildings due to unsuitable materials

The material used for the downstream tubing must be suitable and resistant to deionized water.

2.18.2 Warnings related to hygiene and biology



Warning

Risk of back flow contamination

- Connect the device drain with a free fall to the drain on site to prevent back flow contamination.
-



Warning

Risk of poisoning–Not drinking water

As a product of the reverse osmosis system, the dialysis water does not meet the requirements for drinking water.



Warning

Operator instructions

The device may only be cleaned, disinfected, and preserved by persons who have been instructed on the proper handling of the device during such procedures.

- The operator must observe and follow the general safety precautions.
 - The system may only be disinfected after consultation with the manufacturer of the system or by persons authorized by the manufacturer.
-



Warning**Risk of caustic burning when working with acidic or alkaline substances (concentrated substance or disinfectant/cleaning agent)**

- Be careful when handling acidic or alkaline fluids and do not spill any disinfectant concentrate.
- Rubber gloves (acrylonitrile latex, cotton-lined) should be worn to avoid contact with the skin.
- Wear goggles!
- Observe the safety precautions for the concentrated substance/disinfectant/cleaning agent used.

In the event of contact with acid or alkaline solutions:

Eye: Immediately rinse with running water for 15 minutes.

Skin: Rinse thoroughly under running water and also use soap to neutralize.

Ingestion: Do not induce vomiting, but have the victim drink plenty of non-carbonated water. Seek medical advice.



Note**Risk of infection**

Observe the applicable local laws and regulations concerning the handling of potentially infectious material.

2.18.3 Electrical warnings



Warning**Danger to life caused by electrical voltage**

Touching live parts will cause an electric shock.

- Before opening the device (e.g., for servicing), it must be disconnected from the power and secured against reactivation. Actuating the main On/Off switch stops operation of the device but does not disconnect the device from the supply voltage.
 - Disconnect the power plug to disconnect the device from the power supply.
-



Warning**Danger to life caused by electrical voltage**

- The national standards and regulations must be observed when connecting the system to the power supply system.
 - Do not use any additional extension cables, multiway plugs/connectors, or multiway sockets.
-



Warning**Risk of injury caused by electric shock**

Without a protective ground connection, there is a risk of electric shock.

- Always connect the device to a power supply network with a protective earth conductor.
-

2.19 Patents

Patents apply, visit www.fmcna.com/patents

2.20 Addresses

Manufacturer	Vivonic GmbH Kurfuerst-Eppstein-Ring 4 D-63877 Sailauf Phone: +49 (0)6093 9713-0 Fax: +49 (0)6093 9713-15
Distributor	Fresenius Medical Care North America 920 Winter Street Waltham, MA 02451-1457 USA Customer Service group (800) 323-5188
Service International	Vivonic GmbH Technical Customer Service / Support Kurfuerst-Eppstein-Ring 4 D-63877 Sailauf Phone: +49 (0)6093 9713-23 Fax: +49 (0)6093 9713-214
Local service	Fresenius USA, Inc. Technical Service Department 4040 Nelson Avenue Concord, CA 94520 fmcna.com Technical Service Group (800) 227 2572

3 Design

3.1 Views

3.1.1 Complete device



Legend:

- 1 Main power switch
- 2 **E-box 1**—power electronics
- 3 **E-box 2**—control electronics
- 4 Display as touch screen control element
- 5 Visual indicator
- 6 Cable duct
- 7 Soft water inlet
- 8 Dialysis water outlet
- 9 Dialysis water return
- 10 Concentrate flow, drain
- 11 Membrane pressure vessels
- 12 Break tank
- 13 Booster pumps
- 14 Circulation pump (not visible)

3.1.2 Front view/rear view



Legend:

- 1 Main power switch
- 2 Display as touch screen control element
- 3 **E-box 2**–control electronics
- 4 **E-box 1**–power electronics
- 5 Emergency operation switch
- 6 Booster pumps **P1** and **P2**
- 7 Circulation pump
- 8 Soft water inlet
- 9 Dialysis water outlet
- 10 From ring main
- 11 Concentrate flow, drain
- 12 Drain
- 13 Power supply cord

3.1.3 Side view

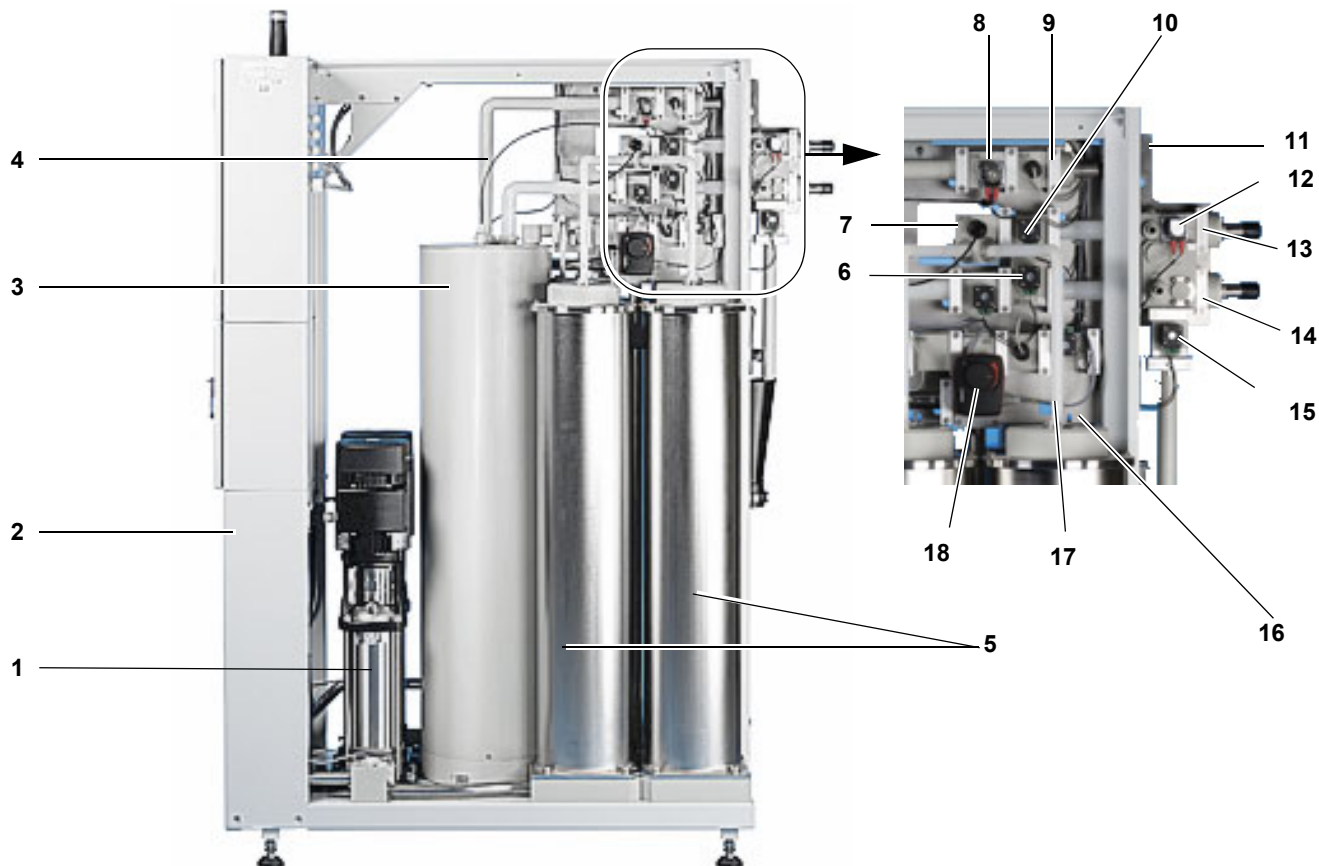
**Legend:**

- 1 Booster pumps
- 2 Circulation pump (not visible)
- 3 Break tank
- 4 Soft water inlet
- 5 Membrane pressure vessels
- 6 Return stop valve
- 7 Dialysis water conductivity sensor
- 8 Water inlet valve and fill valve
- 9 Flow meter, feed
- 10 Dialysis water bypass valve
- 11 Soft water inlet connection, SF clamp
- 12 **RingBase** with sampling and dialysis water flow valve
- 13 Dialysis water feed connection, SF clamp
- 14 Ring return connection, SF clamp
- 15 Ring main drain valve
- 16 Concentrate drain restrictor
- 17 Flow meter, concentrate
- 18 Concentrate restrictor

3.2 Controls and indicators

- **Start-up screen**

After the **AquaA** is switched on, the start-up screen will initially be displayed while the device is booted.

Message displayed: **System start - please wait**

```
CPU  ARM9 200Mhz
MEM  4 MB
SER  200901190028
FIRM TSvisRT_CE 4.4.6 Release
PROT BeckhAdstTCP 4.B Release
TOOL 04.40
FILE AQA_4_40_00_A
TIME 09:33:06
DATE 27.01.21
COUN 2790
RAND 66
IPAD 10.0.0.11
```

The system parameters, the time, the date and all parameters required for the identification of the software are displayed.



3.3 User interface

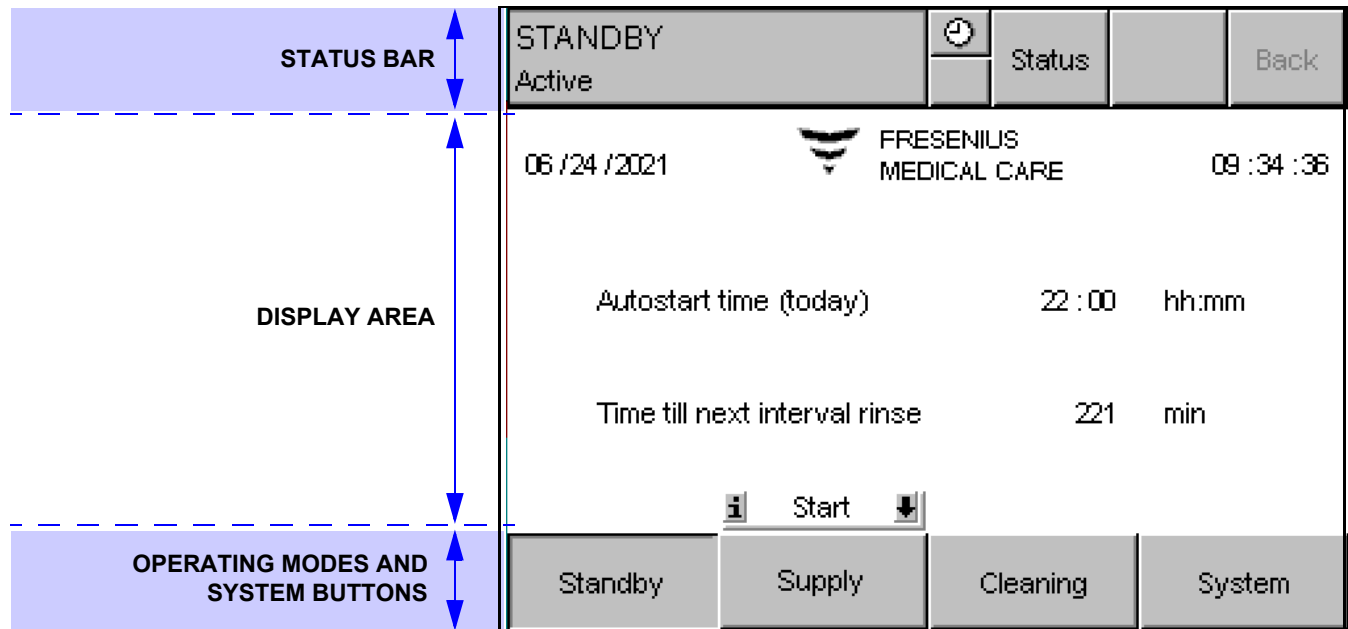

The display is the electronic interface between the operator and the device. The system has a graphical user interface, a feature which has proven useful in many applications and permits practice-oriented operation.



STATUS BAR

The status bar comprises two sections. The first section shows the current operating mode. The second section includes the option to open another menu bar using the **Status** button, in order to display additional information about the device and its components.

The **Back** button can be used to return to the previous menu or display.

Icon	Description
	This icon indicates that a switching program or an interval rinse are waiting in the background for their start. It is also possible to change the current autostop time here. (see chapter 4.5.8 on page 53).
	This icon indicates that a message has not been confirmed.
	This icon is displayed during the preparation phases and alerts the operator that the device is not yet in the desired operating mode.

DISPLAY AREA

Information, messages and, if available, additional selection buttons are displayed in the center of the screen.

OPERATING MODES AND SYSTEM BUTTONS

The currently active operating modes are displayed in the bar at the bottom of the screen. The **System** button provides access to the **Settings** menu (without password) and the **Service** menu (with password).

The buttons can have the following status:

- Inactive buttons (which cannot be selected) are shown grayed out.
- Active buttons and functions are shown in black and depressed.



Note

Avoid damage to the screen

Pointed or sharp objects, such as pens or fingernails, may damage the screen!

3.3.1 Display/touch screen

- **Alphanumeric and numeric entry**

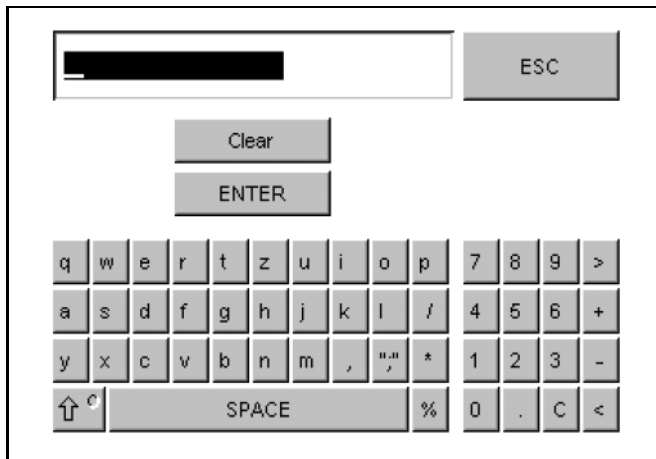

To enter letters and/or digits, the keyboard is displayed as shown in the screenshot.

The **ENTER** button saves the entry.

The **ESC** button is used to exit the display and to cancel the entries.

- **Numeric entry**

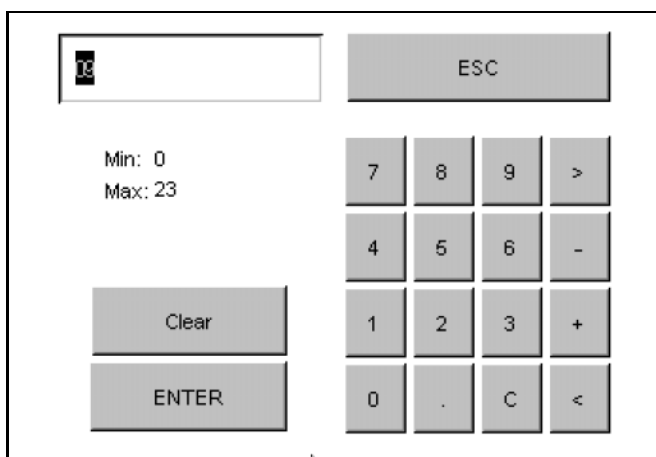

To enter digits, the keyboard is displayed as shown in the screenshot.





The **ENTER** button saves the entry.

The **C** button or the **Clear** button is used to cancel the entry.

The **ESC** button is used to exit the display and to cancel the entries.

- **Visual indicator**

The function of the visual indicator is to inform the operator directly of the current state of the device. Each color indicates a specific status:

Signal color	Description
Red, flashing 	An alarm or a malfunction has occurred and has not yet been confirmed.
Yellow, flashing 	A warning has occurred and has not yet been confirmed.
Yellow 	One of the following operating modes is active: <ul style="list-style-type: none">– Rinse– Service– Disinfection– Heat disinfection
Green 	The device is in SUPPLY Active mode.
Green, flashing 	The device is preparing to switch to SUPPLY or dialysis water storage mode.

4 Operation

4.1 Turning the device on/off

4.1.1 Turning the device on

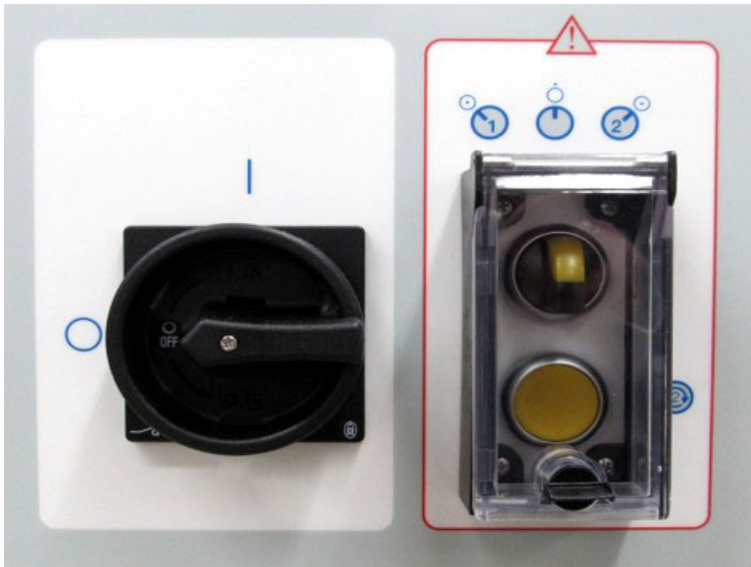

- Turn the device on using the main power switch on the **E-box**.

Main power switch

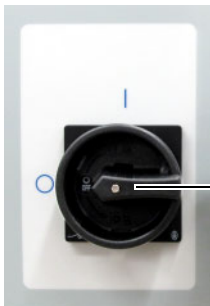

Main power switch
in OFF/O position

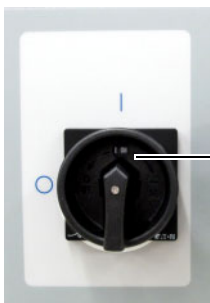

Main power switch
in ON/I position

4.1.2 Turning the device off

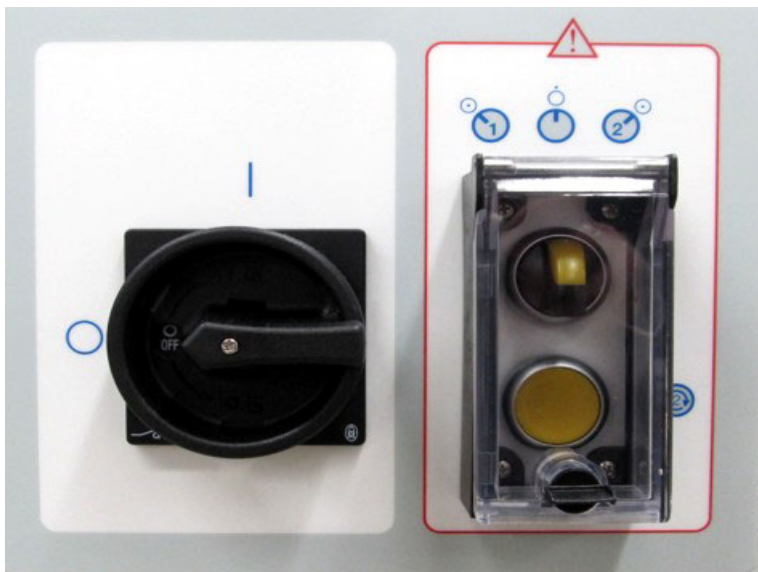

-
- Turn the device off using the main power switch on the **E-box**.

Main power switch

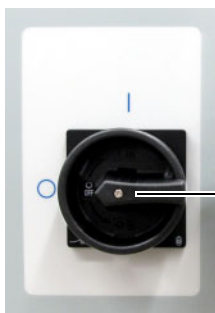

Main power switch
in OFF/O position

4.2 Operating states, sub-operating modes, access permissions

● Access permissions

There are four operating levels with increasing permissions:

- Operator (no password required)
- Authorized operator (with password)
- Clinic technician (**Clinic Technician** training)
- Service technician (**System Technician** training)

● Operating states and sub-operating modes

The **AquaA** provides the following operating states and their sub-operating modes:

Operating state	Sub-operating modes	Persons with access
STANDBY	---	Operator (no password required)
SUPPLY	---	Operator (no password required)
SERVICE	---	Service technician
RINSE	RINSE Active	Operator (no password required)
	RINSE-Water pretreatment	Operator (no password required)
CLEANING	DECALCIFICATION	Clinic technician
	ALKALINE CLEANING	Clinic technician
DISINFECTION	DISINFECTION	Clinic technician
	DISINFECTION SERVICE	Service technician
	DISINFECTION INTERFACE	Service technician
HEAT DISINFECTION	HEAT DISINFECTION (MODULES)	Authorized operator
	HEAT DISINFECTION (RING MAIN)	

Operating state	Sub-operating modes	Persons with access
EMERGENCY MODE	EMERGENCY MODE (AquaA)	Authorized operator
---	EMERGENCY MODE (AquaA2 option)	Authorized operator
---	EMERGENCY MODE (AquaUF option)	Authorized operator

4.3 Device status STANDBY

4.3.1 Booting the system

While the following screens are displayed, the application is started and communications between PC control and display are established.



Note

Interruption of booting

Do not touch the display during the boot process, as inadvertent entries made on the keyboard during booting can interrupt the boot process.

```
CPU  ARM9 200Mhz
MEM  4 MB
SER  200901190028
FIRM TSvisRT_CE 4.4.6 Release
PROT BeckhAdstTCP 4.B Release
TOOL 04.40
FILE AQA_4_40_00_A
TIME 09:33:06
DATE 27.01.21
COUN 2790
RAND 66
IPAD 10.0.0.11
```

The processor data are displayed.

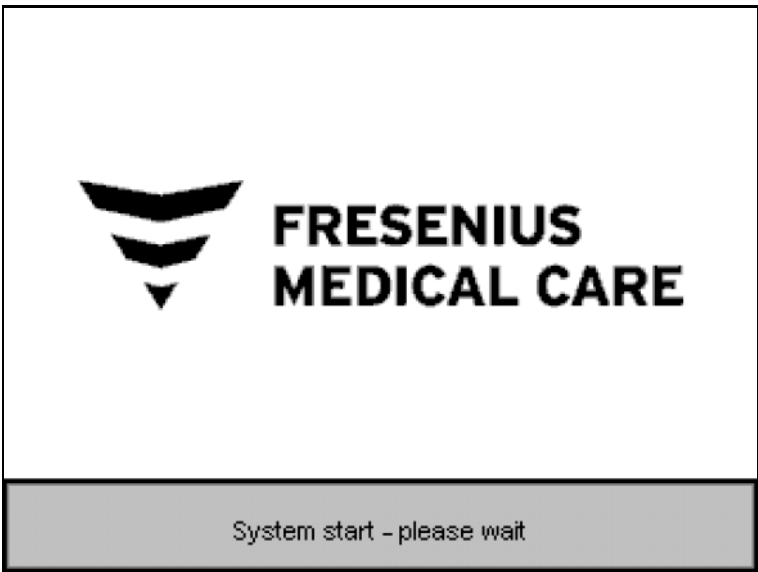

The system start may take up to 20 seconds. During this phase the device is not yet ready for operation.

4.4 STANDBY operating state

- Operating modes—overview

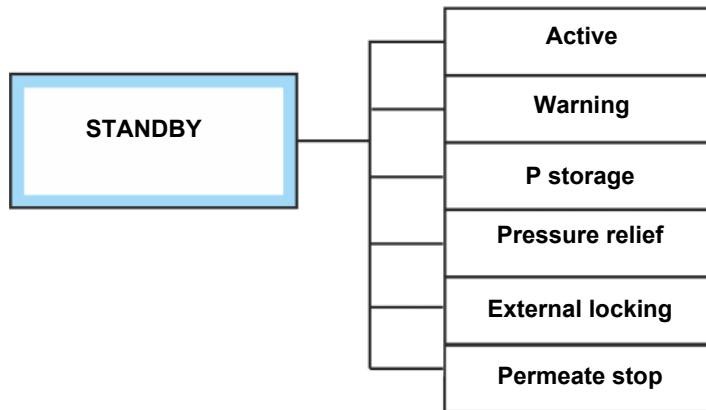

4.4.1 STANDBY–Active

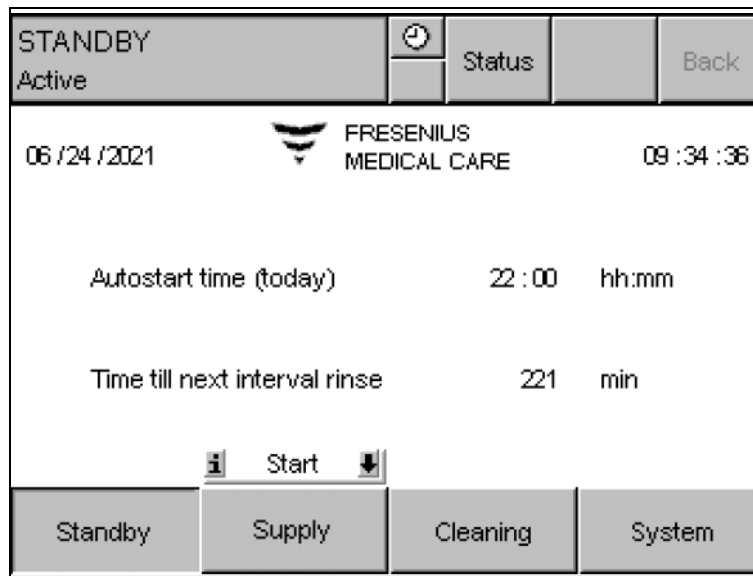

In the **STANDBY** mode the electronics are active, but the device is technically still idle.

During the **STANDBY–Active** mode, the control unit of the device is active. The display shows the time for the next **Autostart** and the remaining time until the start of the next automatic rinse.

4.4.2 STANDBY–Warning

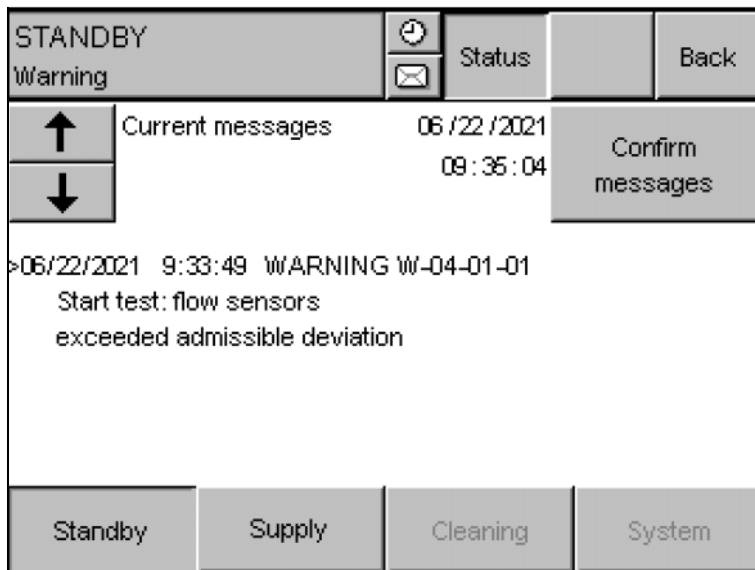

During **STANDBY–Warning** mode, the **AquaA** is still operational but requires an analysis of the warning (see chapter 5).

The display shows the current values or the list of messages with the current message.

4.4.3 STANDBY–P storage (permeate or dialysis water storage)

After the device has been turned off, the level in the break tank is lowered and all of the concentrate is discarded via the concentrate drain valve. Once the level in the break tank has been lowered to **NIV2**, the device will switch to the **STANDBY–Active** mode.

This procedure is used to store the membranes of the **AquaA** in pure water (high dialysis water content). This procedure is carried out each time before **STANDBY** mode is started and results in an increased consumption of water. The storage in permeate function is activated by the service technician in the Service menu of the **AquaA**.

4.4.4 STANDBY–Permeate stop

If the conductivity or temperature alarm limit is exceeded during **STANDBY** mode, the dialysis water flow valve will be closed. No more dialysis water (permeate) is then supplied to the treatment area. The display shows the current values or the list of messages with the current message.

4.4.5 STANDBY–External locking

In this operating mode, the functionality of the **AquaA** is limited due to a water pretreatment system signal. There is an insufficient supply of water to the **AquaA**. No programmed operating modes are started automatically.

The **RINSE** mode can, however, continue to be started manually. The water supply to the **AquaA** remains locked. The external locking function is configured by the service technician in the Service menu of the **AquaA**.

4.5 SUPPLY operating state

- Operating modes—overview

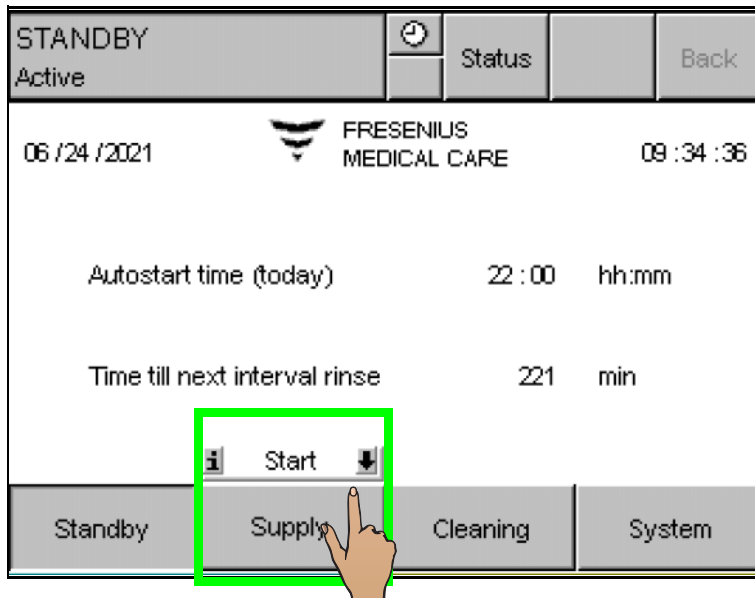
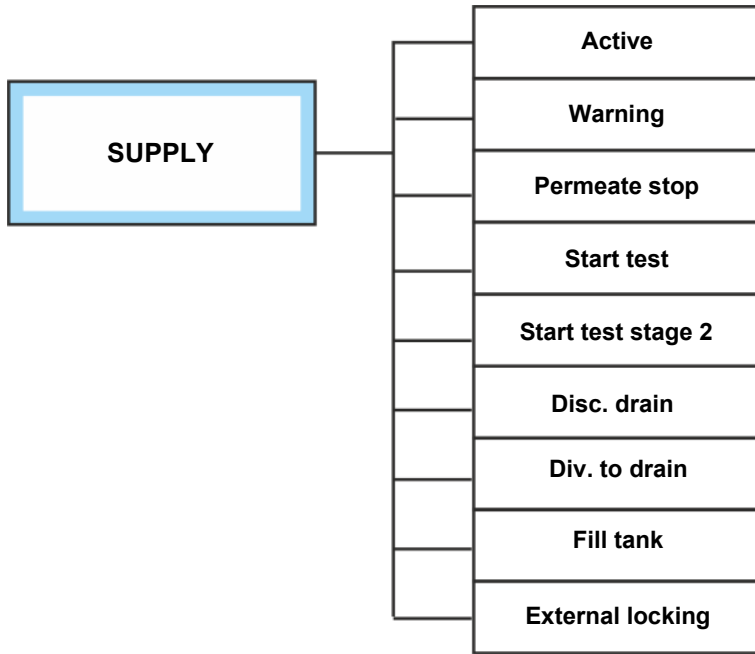

The **SUPPLY** mode is started by pressing and holding the **Supply** button on the display for 3 seconds, or is activated by the programmed switching program.

The **SUPPLY** mode can be started from the modes **STANDBY–Active** or **RINSE**.

This screen shows the main screen in the **STANDBY–Active** mode.

4.5.1 SUPPLY–Start test

The start of the **SUPPLY** mode is confirmed by a change of the screen. Simultaneously the reverse osmosis system is started in the **SUPPLY** mode.

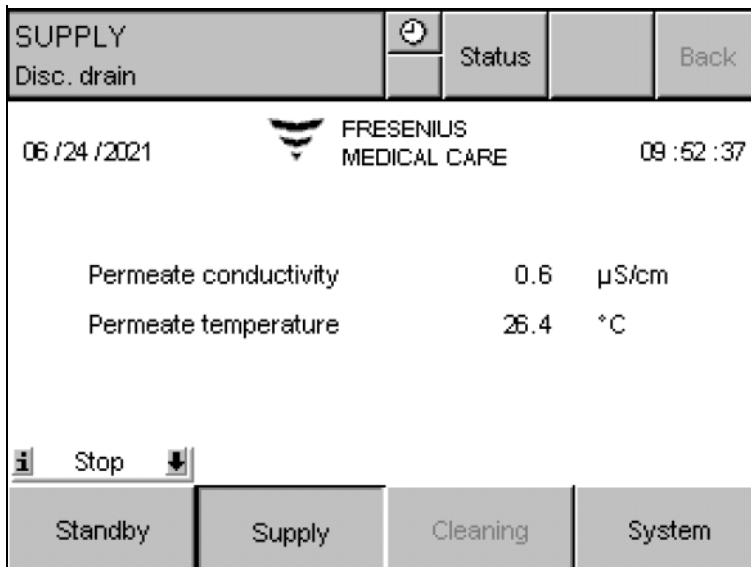

While the system is started in the **Start test** mode, the following 5 steps are performed.

Start phase 1

- Fill break tank
- Start pump **P1**
- Set operating point
- Start pump **P3**
- Further checks (conductivity and temperature sensors, flow sensor checks)

If an **AquaA2** is connected, the following phases will be performed:

Start phase 2

- Rinse concentrate return
- Rinse dialysis water path
- Start pump **P1s**
- Start pump **P3s**
- Further checks (conductivity and temperature sensors, flow sensor checks)

The start phases are now complete.



Note

If the **AquaA** is to be operated continuously in the **SUPPLY** mode, it is recommended to be switched once a day and least once per week from **SUPPLY** to **STANDBY** (and back) to run the **Start test**.

4.5.2 SUPPLY–Active

In the **SUPPLY** mode, the **AquaA** reverse osmosis system produces dialysis water. In this mode the device controls the programmed yield and monitors all relevant parameters.

4.5.2.1 Yield control

The yield control is active in the **SUPPLY** and the **RINSE** mode. The control can be both continuous or intermittent. Switching between the two control types is done automatically.

The goal of the yield control is to achieve the programmed efficiency. The concentrated water to be discarded as well as the flow sensor checks are determined based on the current inflow and the calculated dialysis water consumption.

In special situations the efficiency may deviate from the specified value (exceeded alarm limits).

In case calculation of a plausible volume which is to be discarded is impossible due to a defect of the measuring transducers, the yield control will be replaced by static default values.

4.5.2.2 Continuous control

During continuous control, the concentrate volume to be discarded is calculated on the basis of the programmed efficiency and is adjusted with the concentrate restrictor.

4.5.2.3 Intermittent control

This control mode is automatically selected for diversion of small concentrate volumes. During this control mode the diversion volume is calculated and is discarded at intervals. The efficiency is calculated at the end of the diversion interval. This operating mode is indicated on the display by **SUPPLY-Disc. drain**.

4.5.3 SUPPLY–Div. to drain

This operating mode is selected if an alarm limit has been exceeded or if a value is close to the alarm limit. This will reduce the current efficiency by 10%, but not lower than 50%.

4.5.4 SUPPLY–Permeate stop

- **Dialysis water conductivity and temperature monitoring**

If the conductivity or temperature alarm limit is exceeded, the dialysis water supply will be stopped by the closing of the dialysis water flow valve. Yield control is deactivated during this time.

4.5.5 SUPPLY–Warning

During **SUPPLY–Warning** mode, the **AquaA** is still operational but requires an analysis of the warning (see chapter 5.3.1 on page 111).

The display shows the current values or the list of messages with the current message.

4.5.6 SUPPLY–External locking

In this operating mode, the functionality of the **AquaA** is limited due to a water pretreatment system signal. There is an insufficient supply of water to the **AquaA**. The supply of water from the water pretreatment system to the **AquaA** is blocked as a precautionary measure. A run-dry protection warning will therefore appear if dialysis water is consumed.

Once the water pretreatment system reports an adequate water supply, the valve will be reopened.

The external locking function is configured by the service technician in the Service menu of the **AquaA**.

4.5.7 SUPPLY–Fill tank

SUPPLY Fill tank			Status	Back
06 /24 /2021		FRESENIUS MEDICAL CARE	11 :48 :58	
Permeate conductivity	0.2	µS/cm		
Permeate temperature	13.5	°C		
Stop				
Standby	Supply	Cleaning	System	

If a fill request from an external tank is received, the **AquaA** is automatically switched to the **SUPPLY–Fill tank** mode. When this mode starts, the **Start test** is carried out, and the device subsequently produces dialysis water for the ring main and the connected tank.

In this mode the device controls the programmed yield and monitors all relevant parameters. After filling the tank, the **AquaA** switches back to the **STANDBY** mode.

SUPPLY Fill tank			Status	Back
06 /24 /2021		FRESENIUS MEDICAL CARE	11 :49 :55	
Permeate conductivity	0.2	µS/cm		
Permeate temperature	13.6	°C		
Automatic shutoff after filling tank!				
Stop				
Standby	Supply	Cleaning	System	

The **AquaA** accepts the operator input to switch to the **STANDBY** mode and will initiate the switching function later.

➤ This switching delay is confirmed by the *Automatic shutoff after filling tank!* message.



Note

The **AquaA** will not switch to **STANDBY** mode if a switching program is active in **Autostart**.

4.5.8 SUPPLY–Changing the Autostop time

SUPPLY		Status	Back
Start test			
Change Autostop time for today			
Current time	09 : 33	(hh : mm)	
Autostop time	13 : 00		
New Autostop time	16 : 00		Confirm
Standby	Supply	Cleaning	System

If a switching program is active, the stop time can be changed individually.

This change can result in an extension or a reduction of the switching program time.

- To change the **Autostop** time, select the clock symbol.
- Enter the new **Autostop** time in the New **Autostop** time field. If the new Autostop time occurs on the next day, it must be later than the current **Autostart** time.
- The new time is stored by pressing the **Confirm** button.

4.6 RINSE operating state

- Operating modes—overview

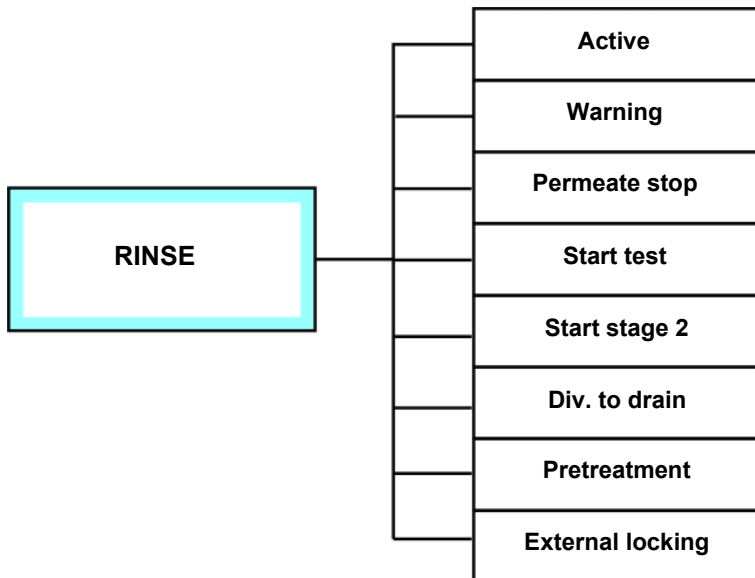

The **RINSE** mode can either be started manually via the display or via the **RINSE** switching program. The time until the next interval rinse is shown on the display.

Additionally, rinsing the water pretreatment system will achieve a high flow of water through the active carbon filters, ensuring that the subsequent measurement of the chlorine content meets the requirements of ISO 23500-1 (or ISO 23500 respectively).



Note

When external locking is active, the ability to start the **RINSE** switching program is blocked.

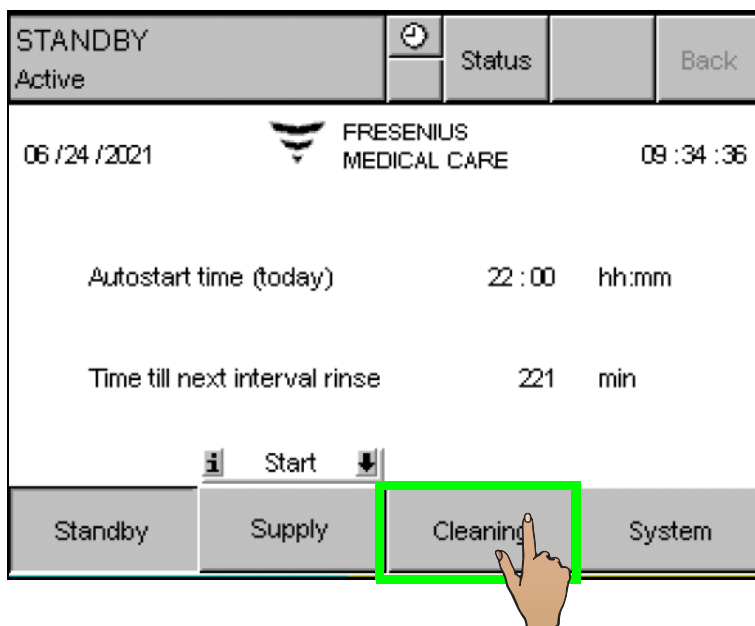

To manually start **RINSE** mode, press the **Cleaning** button on the display.

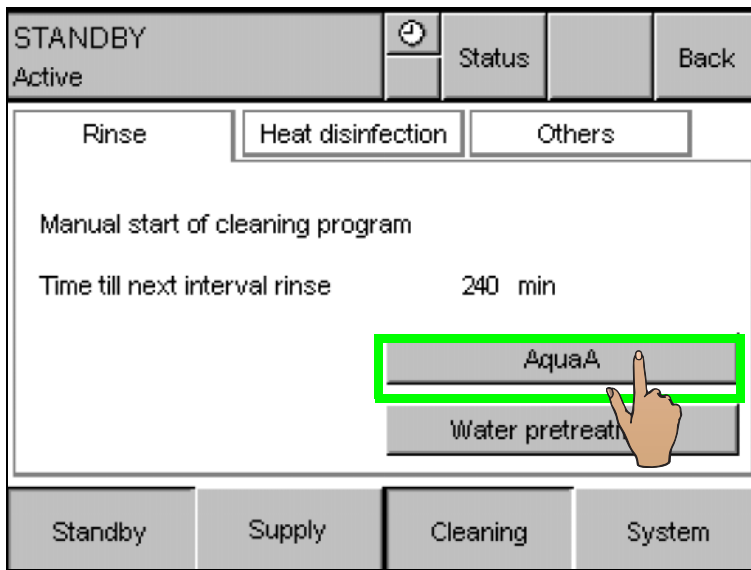

To start **RINSE** mode, press the **AquaA** button.

4.6.1 Preparing for RINSE

RINSE		Status	Back
Active			
06 / 24 / 2021	 FRESENIUS MEDICAL CARE		10 : 16 : 27
Permeate conductivity	0.4	μS/cm	
Residual volume diversion	74	liters	
Remaining rinse time	12	min	
Standby	Supply	Cleaning	System

The start of the **RINSE** mode is confirmed by a change of the screen. Simultaneously the reverse osmosis system is started in the **RINSE** mode.

- **The start of the reverse osmosis system is divided in 5 steps.**
 - Fill break tank
 - Start pump **P1**
 - Set operating point
 - Start pump **P3**
 - Release dialysis water

- **If an AquaA2 is connected, the following phases will be performed:**
 - Rinse concentrate return
 - Rinse dialysis water path
 - Start pump **P1s**
 - Start pump **P3s**
 - Release dialysis water

4.6.2 RINSE-Active

RINSE		Status	Back
Active			
06 / 24 / 2021	 FRESENIUS MEDICAL CARE		10 : 16 : 27
Permeate conductivity	0.4	$\mu\text{S}/\text{cm}$	
Residual volume diversion	74	liters	
Remaining rinse time	12	min	
Standby	Supply	Cleaning	System

The device is cleaned with water by rinsing all line branches and by replacing the specified volume to be diverted (see chapter 4.11.3.4 on page 98).

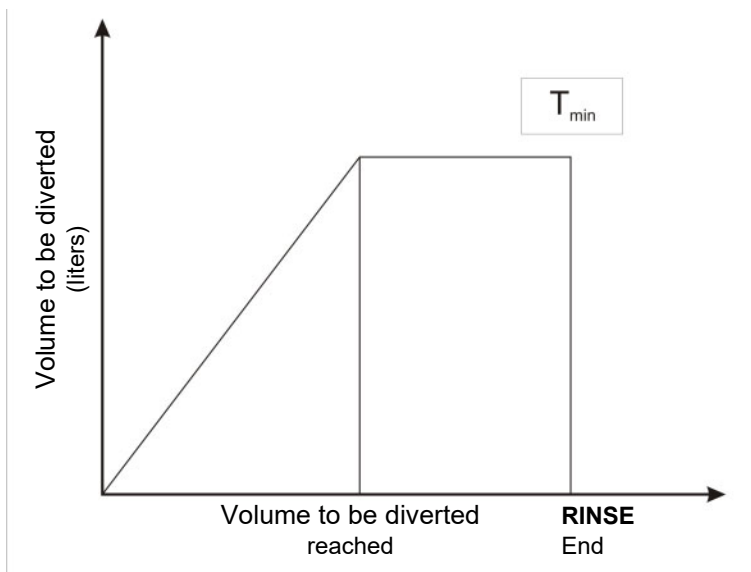

If the specified volume to be diverted is reached within the specified minimum rinse time, the device will continue to operate in the circulation mode for the remaining minimum time.

4.6.3 RINSE–Water pretreatment

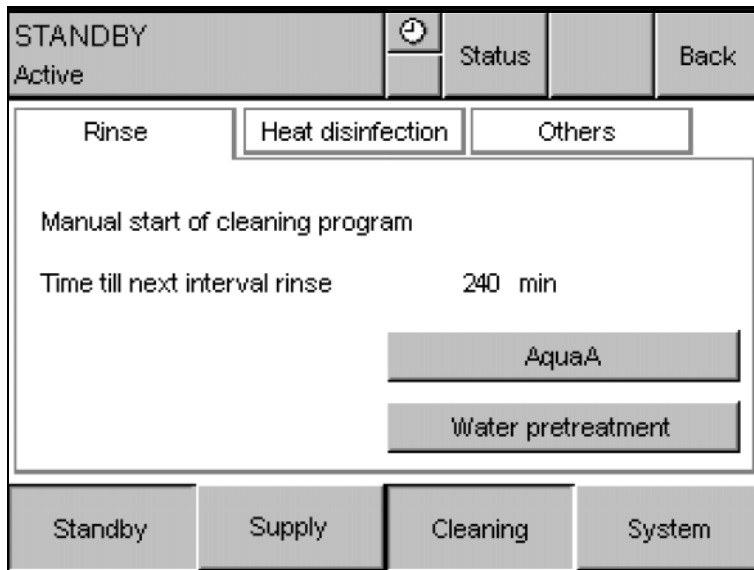

To start **RINSE-Water pretreatment** mode, press the **Water pretreatment** button.

The device is cleaned with water by rinsing all line branches, and results in a maximum possible water consumption for the programmed time. This rinses the filters of the water pretreatment system, thereby ensuring the requirements of ISO 23500-1 (or ISO 23500 respectively) for active carbon filters are met.

4.7 DISINFECTION operating state



Note

Applicable regulations for disinfection

For all activities regarding the disinfection, the directives, regulations and safety precautions for safe handling of disinfectants apply.

In addition to these, the general safety precautions for cleaning and disinfection must be followed when disinfecting the **AquaA** (see chapter 6 on page 131).



Note

External locking of the water pretreatment system locks the water inlet valve, (see chapter 4.5.6 on page 51).

● Operating modes—overview

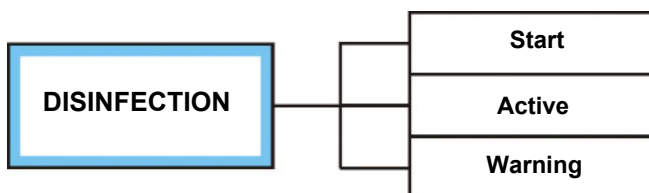

DISINFECTION mode requires clinic technician (**Clinic Technician** training) or service technician (**System Technician** training) access permissions.

4.8 EMERGENCY MODE operating state

4.8.1 General information



Warning

Unpredictable device response

Some essential program functions are inactive during emergency mode.

EMERGENCY MODE is only designed for short-term use (e.g., to complete the dialysis treatment in progress; maximum 120 hours).

- The issue which caused the device to switch to emergency mode must be eliminated immediately to resume normal operation.



Warning

Emergency mode after a disinfection

- The **EMERGENCY MODE** may not be started if there is still residual disinfectant in the system after a disinfection.

● **Operating modes—overview**



Emergency mode screen

During **EMERGENCY MODE** the electronic control is bypassed.

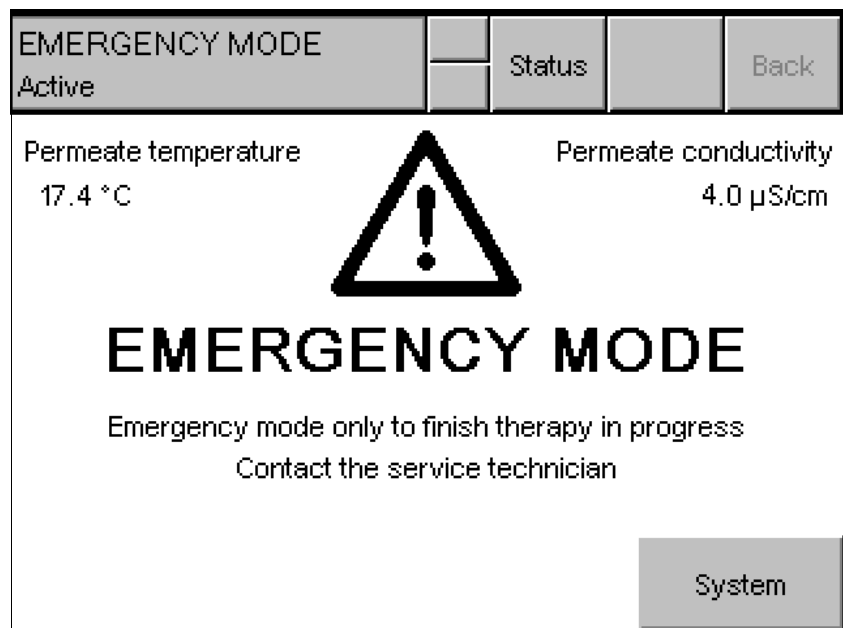

In general

As the **AquaA** reverse osmosis system has been designed to be highly fail-safe, an emergency provision for soft water supply was not included.

The **Status** and the **SYSTEM** menu can be accessed during the **EMERGENCY MODE**.

The second booster pump can be activated by pressing the button shown below.



This may be necessary if the device runs at maximum capacity.

**Note**

Emergency operation is only available for the **AquaA** reverse osmosis system.

The connected devices (**AquaA2** etc.) will not be activated.

● Activating the emergency mode**Note**

The dialysis water conductivity and the feed temperature are monitored during this operating mode. A dry-run protection is also active.

4.8.2 Turning AquaA EMERGENCY MODE on

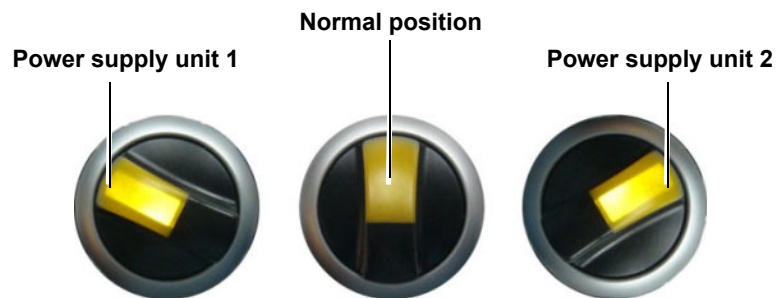
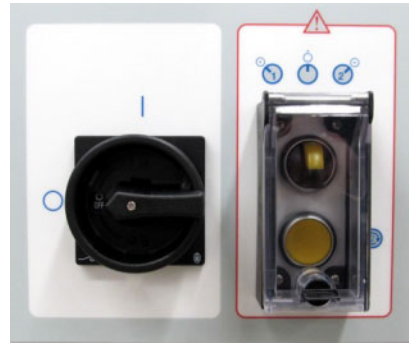

The EMERGENCY MODE is initiated by the following steps:

Step 1 ➤ Turn the reverse osmosis system and all other devices (**AquaA2**, **AquaHT** etc.) off using the main power switch (**OFF/O** position)

Step 2 **Change the position of the emergency operation switch**
➤ The button can be turned either to the left or to the right.



This selects the power supply unit and turns pump **P1** on.

Step 3 ➤ Return the main power switch of the **AquaA** to the **ON/I** position.
Information on booting the system (see chapter 4.3.1 on page 44).

Step 4 This step deactivates the actuator outputs of the electronic control so that no actions can be performed.
➤ If pump **P1** did not turn on, set the switch to the other position. To do so, restart at step 1 and use the emergency operation switch setting 2 in step 2.

Step 5 ➤ By pressing the button for pump **P2**, the produced volume of dialysis water can be increased.



- Pump **P2** can also be turned on as a backup in case pump **P1** cannot be turned on.

4.8.3 Turning AquaA EMERGENCY MODE off

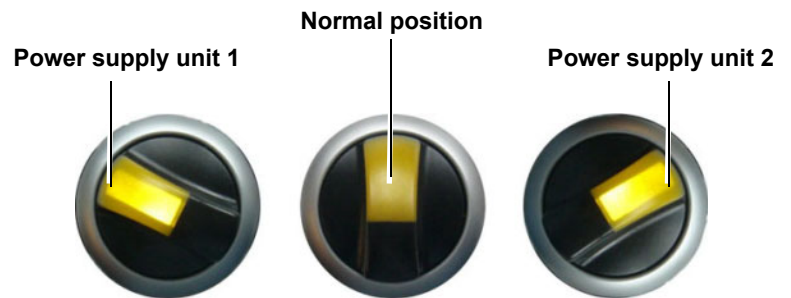

When turning off the EMERGENCY MODE, observe the steps listed below.

- Step 1**
 - Set the main power switch of the **AquaA** to the **OFF/O** position.
- Step 2**
 - Set the emergency switch to its center position.
- Step 3**
 - Return the main power switch of the **AquaA** to the **ON/I** position.
- Step 4**
 - Return the main power switches of all devices (**AquaA**, **AquaA2**, **AquaHT** etc.) to the **ON/I** position.

4.8.4 AquaA2 EMERGENCY MODE (option)

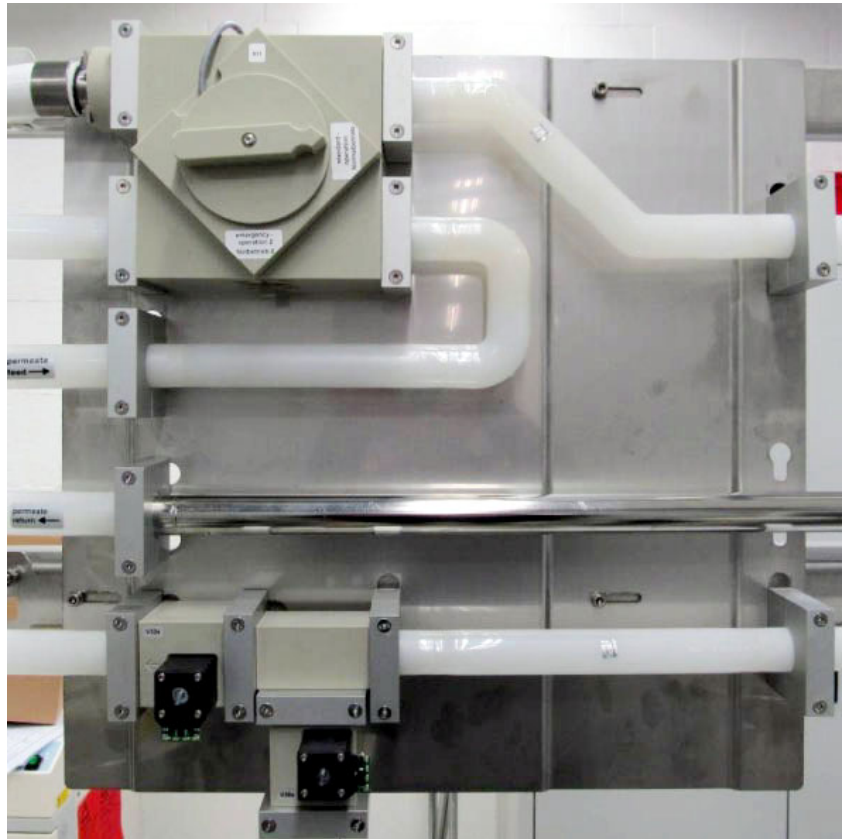

As the **AquaA2** reverse osmosis system has been designed to be highly fail-safe, an emergency provision for soft water supply was not included.



Note

While it is in **EMERGENCY MODE**, the **AquaA** is turned off and no values will be displayed.



Note

In **EMERGENCY MODE** mode, the dialysis water conductivity and the volume of inlet water are monitored.

4.8.5 Turning AquaA2 EMERGENCY MODE on

Step 1

Relieve pressure (optional):

- Shut off the water supply to the **AquaA** and relieve the water pressure.
- Turn off **AquaA**, **AquaA2** and **AquaHT** at main power switch (position **OFF/O**).

Step 2

Change the water supply path:

- Turn the emergency mode switch on the wall counterclockwise to the **emergency operation 2** position.

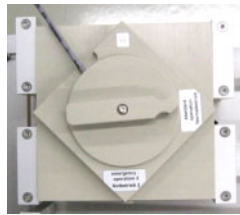

Open water inlet (optional, if Step 1 has been performed).

- Open the water inlet to the **AquaA**.

Step 3

Change the position of the emergency operation switch:

To do so, turn the switch to the right.

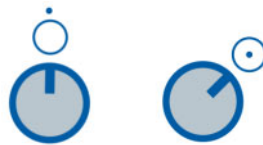

This selects the power supply unit and turns pump **P1s** on.

Step 4

Return the **AquaA2** main power switch to the **ON/I** position.

This deactivates the actuator outputs of the electronic control so that no actions can be performed.

The drain valve and dialysis water flow valve are activated and opened. The dialysis water flow valve is opened depending on the dialysis water conductivity.

Step 5

The button for pump **P2s** can be used to increase the produced volume of dialysis water.

Pump **P2s** can also be turned on as a backup in case pump **P1s** can not be turned on.



4.8.6 Turning AquaA2 EMERGENCY MODE off

When turning the emergency mode off, the following steps must be observed:

Step 1

Set the main power switch to the **OFF/O** position.

Step 2

Set the emergency switch to its center position.

Step 3

Change the water supply path.

Turn the emergency mode switch on the wall clockwise to the **Standard operation 1** position.

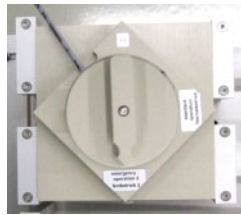

Step 4

Return all main power switches to the **ON/I** position.



Warning

Risk of contamination

- A chemical disinfection or module heat disinfection is required once **EMERGENCY MODE** has ended.
-

4.8.7 AquaUF EMERGENCY MODE (option)

In the event of a malfunction, the **AquaUF** module can be bypassed.



Warning

Risk of contamination

After servicing the dialysis water circuit, the device must be disinfected.

To reroute the dialysis water supply, carry out the following steps:

- Step 1** Switch the **AquaA** to **STANDBY** and wait for **STANDBY–Active** mode.
- Step 2** Turn off **AquaA**, **AquaA2** and **AquaHT** and at the main power switch (**OFF/O** position).
- Step 3** Open and remove the clamp on the left pipe elbow.

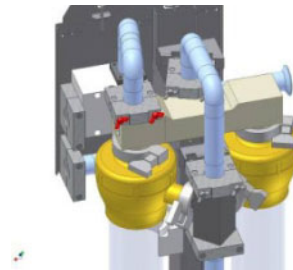

- Step 4** Open both clamps on the center pipe elbow.

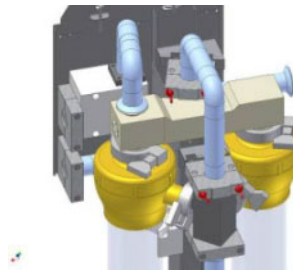

- Step 5** Remove the center pipe elbow.

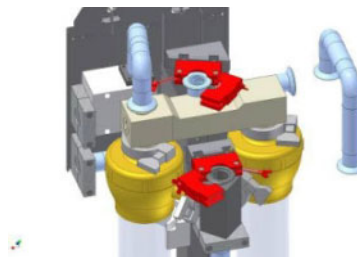

- Step 6** Swivel the left pipe elbow on the front to the right and close it again using the clamp.



Note

- Tighten the clamp connections using 2.5 Nm of torque.

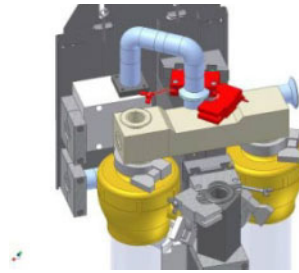

Step 7

Turn on **AquaA**, **AquaA2** and **AquaHT** again at the main power switch (**ON/I** position)

4.9 FAILURE

If alarm limits that require a pump stop are exceeded, **FAILURE - Pump stop** mode is activated.

In this operating mode, the **AquaA** goes into the safe state, switches off all pumps, and locks all relevant valves.

This operating mode can only be exited by the operator once no causative failure is active any more.

4.10 STATUS–Menu

When pressing the **Status** button, a selection menu with five sub-menus will be displayed:

- **Menu structure–overview**

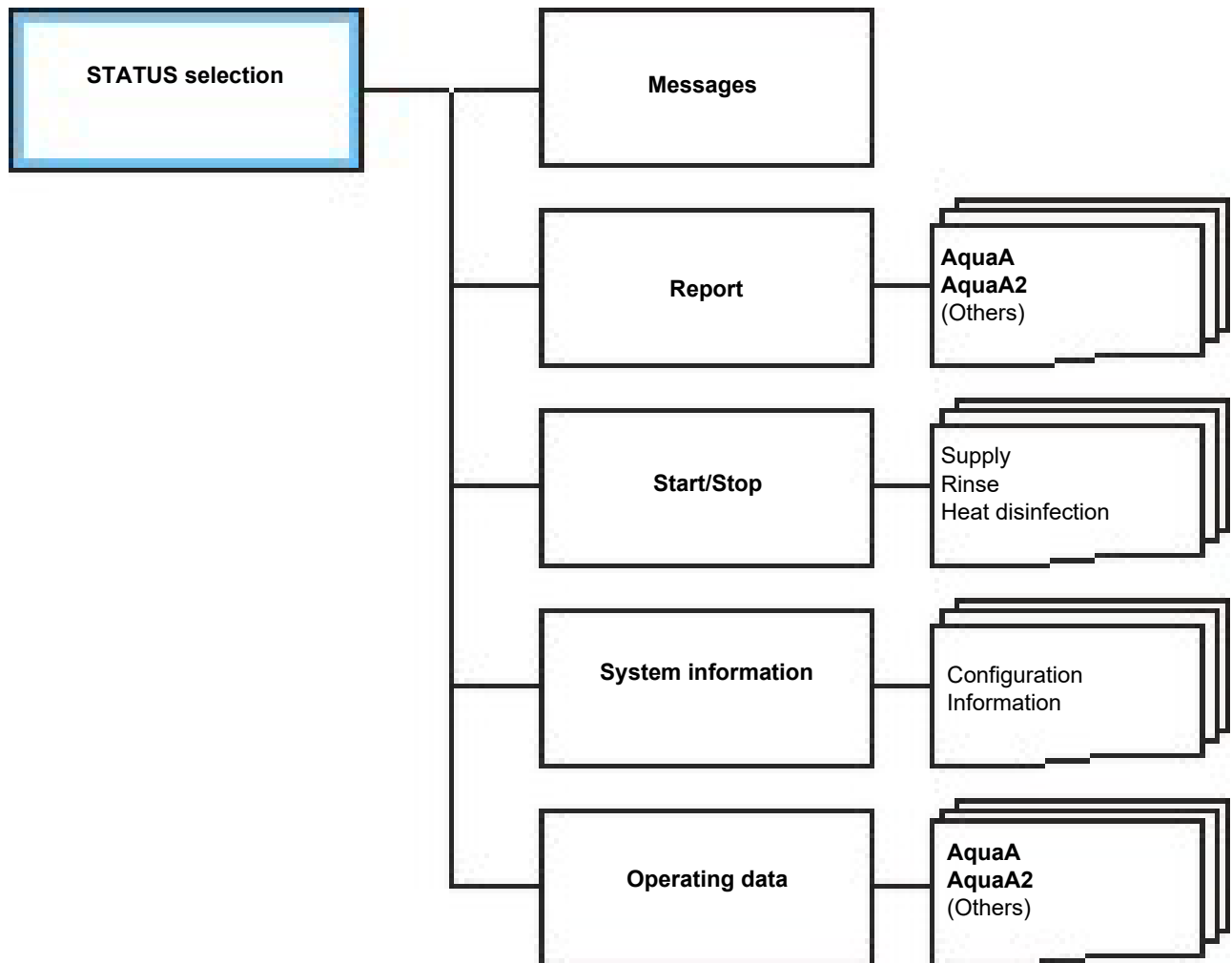

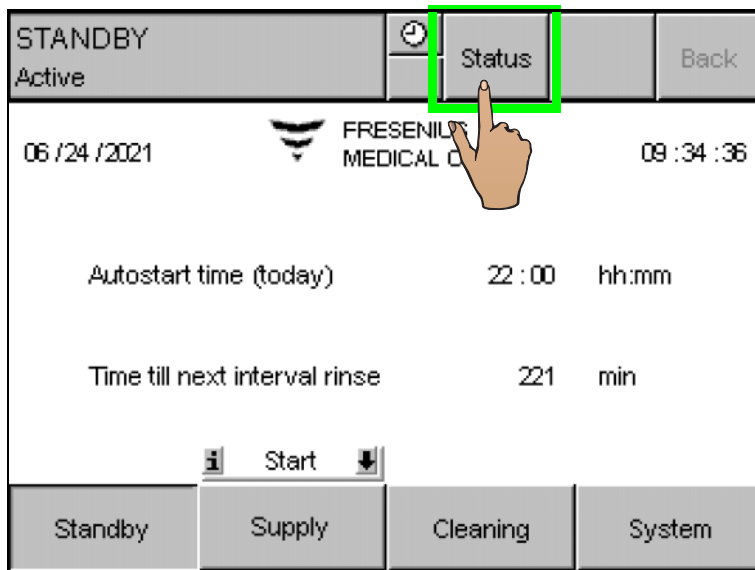

When selecting the **Status** button, the following selection menu with status screens is displayed.

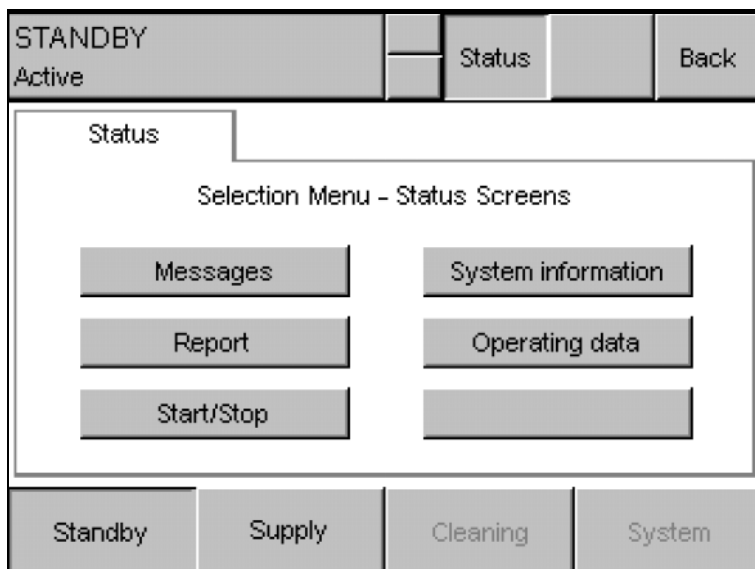

The layout of the **Selection Menu–Status Screens** is shown in the Menu structure–overview.

This menu is organized in the following status screens:

Messages:

- Displays the current messages

Report:

- Displays the daily report and the heat disinfection report page by page, as well as a report on the most recent activities of the **AquaA**.

Start-Stop:

- Displays the current switching program settings.

System information:

- Displays the current system configuration and other system information.

Operating data:

- Displays the current operating data of the water treatment system.

4.10.1 STATUS–Messages

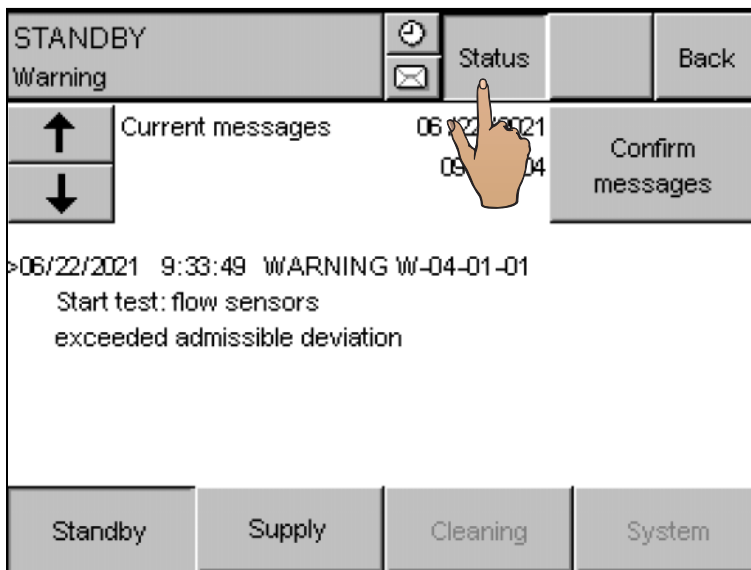

The current error messages are displayed by pressing the **Status** button. The **Messages** screen can be displayed as described, but can also be displayed directly if an alarm occurs.

All alarms which occurred are shown in chronological order (see Error messages in chronological order).

For a description of the individual messages, refer to the Alarms chapter (see chapter 5.3 on page 111).



Tip

Active messages (alarms caused by problems which have not yet been corrected) cannot be confirmed and deleted.

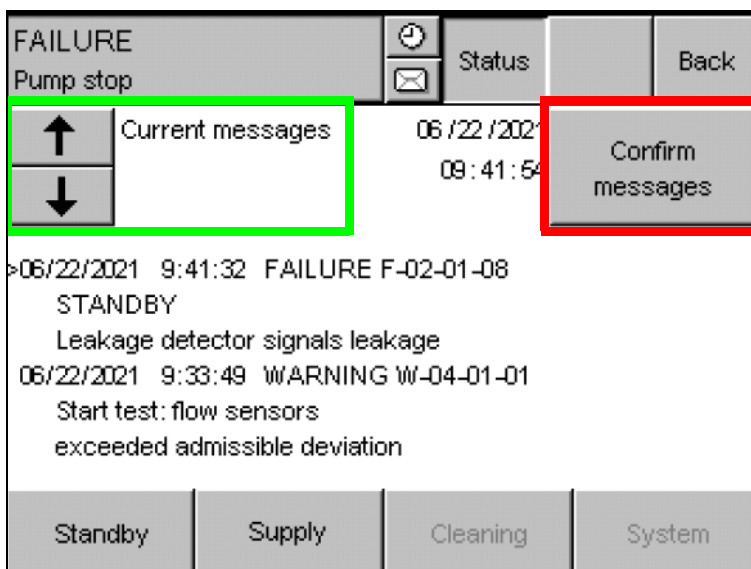

The **Messages** window can display two messages at a time. If more than two messages are present, the message text *More messages present!* is displayed.

Select the desired message using the **Arrow** button (green frame).

To confirm all messages and delete them from the list, use the button **Confirm messages** (red frame).

The **Back** button can be used to return to the previous menu or display.

4.10.2 STATUS–Report

● Menu structure–overview

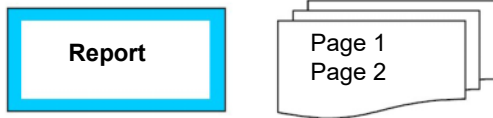

The daily reports are displayed by pressing the **Report** button.

4.10.2.1 Daily report AquaA

STANDBY		Status		Back				
Active								
AquaA		AquaA 2		others				
Daily report	CD-F	T-F	CD-P	T-P	P-C	P-P	FL-F	max
	µS/cm	°C	µS/cm	°C	bar	bar	L/min	L/min
06/27 09:00	52	20	3	20	7.6	4.1	13	112
06/26 09:00	52	19	3	19	7.8	4.1	10	110
06/25 09:00	54	19	3	19	7.8	4.2	9	110
06/24 09:00	19	27	3	27	7.5	4.6	0	111
06/23 09:00	17	26	3	26	7.5	4.6	0	111
06/20 09:00	22	28	2	28	7.4	5.2	7	93
06/19 09:00	23	29	3	30	7.3	5.3	6	93

In the daily report, the current data of the device in the **SUPPLY** mode are recorded every day at a programmed time. These data are intended to assist the technician when analyzing the device.

The following data are recorded:

- Date and time when the data was collected
- Feed conductivity **CD-F**
- Feed temperature **T-F**
- Dialysis water conductivity **CD-P**
- Dialysis water temperature **T-P**
- Concentrate pressure **P-C**
- Permeate pressure **P-P**
- Feed flow **FL-F**
- Maximum feed flow **FL-Fmax**



Tip

More values are shown on the second page.

STANDBY		Status		Back	
Active					
AquaA		AquaA 2		others	
Daily report					
	FL-C	Rej.	FL-Pstd.	Consum.	Total
	L/min	%	L/min	L/day	m ³
06/27 09:00	4	98.0	47	3116	25
06/26 09:00	3	98.3	45	5302	23
06/25 09:00	1	99.0	46	3480	18
06/24 09:00	0	100.0	52	2381	14
06/23 09:00	0	100.0	50	2693	12
06/20 09:00	7	89.3	162	3101	5
06/19 09:00	6	100.0	162	1079	2
Standby		Supply		Cleaning	
				System	

Data of the previous day:

- Date and time
- Concentrate flow **FL-C**
- Rejection rate **Rej.**
- Standardized dialysis water flow **FL-Pstd**
- Water consumption of the previous day
- Total water consumption

4.10.2.2 Daily report AquaA2

In the daily report, the current data of the device in the **SUPPLY** mode are recorded every day at a programmed time. These data are intended to assist the technician when analyzing the device.

STANDBY		Status		Back	
Active					
AquaA		AquaA 2		others	
Daily report					
	CD-Ps	T-Ps	P-Fs	P-Cs	P-Ps
	μS/cm	°C	bar	bar	bar
	FL-Fs	FL-Cs	Rej.s		
	L/min	L/min	%		
06/27 09:00	0.5	21	3.3	7.3	4.4
06/26 09:00	0.3	20	3.3	7.3	4.4
06/25 09:00	0.4	20	3.3	7.3	4.4
06/24 09:00	0.6	28	3.7	7.5	5.1
06/23 09:00	0.5	26	3.7	7.6	5.1
06/20 09:00	7.7	20	0.3	0.1	0.9
06/19 09:00	7.7	20	0.3	0.1	0.9
Standby		Supply		Cleaning	
				System	

The following data are recorded:

- Date and time when the data was collected
- Dialysis water conductivity **CD-Ps**
- Dialysis water temperature **T-Ps**
- Feed pressure sensor **P-Fs**
- Concentrate pressure **P-Cs**
- Permeate pressure **P-Ps**
- Feed flow **FL-Fs**
- Concentrate flow **FL-Cs**
- Rejection rate **Rej.**

4.10.2.3 Daily report AquaHT



Note

Report of previous heat disinfections

The report of the last 7 heat disinfection programs performed can be viewed by selecting the **others** tab and then the **Heat disinfection** menu option.

STANDBY		Status		Back			
Active							
AquaA		AquaA 2		AquaHT			
Report	Duration	Type	Temp. 1	Temp. 2	Consum.	A0	
	min		°C	°C	liters		
06/25 11:18	164	Module	81	80	133	924	
06/24 11:42	113	Ring main	79	74	216	562	
06/23 10:21	118	Ring main	81	76	222	904	
06/22 17:46	165	Module	81	80	142	913	
06/22 13:39	122	Ring main	76	71	192	276	
-	-	0	0	0	0	0	
-	-	0	0	0	0	0	
Standby		Supply		Cleaning		System	

This report shows the following data:

- Start of the heat disinfection program
- Duration of the heat disinfection program
- Type of heat disinfection program
 - Ring: Ring main
 - Module
 - Uni: ring main followed by module heat disinfection
- Temp 1: Temperature 1 reached
 - Ring main: feed temperature
 - Module: feed temperature
- Temp 2: Temperature 2 reached
 - Ring main: Return temperature
 - Module: Dialysis water temperature
- Consum.: Product water consumption from the **AquaHT** tank during heat disinfection.
- A0: The A0 value (according to EN ISO 15883-1) achieved during heat disinfection

4.10.2.4 Report on the most recent activities

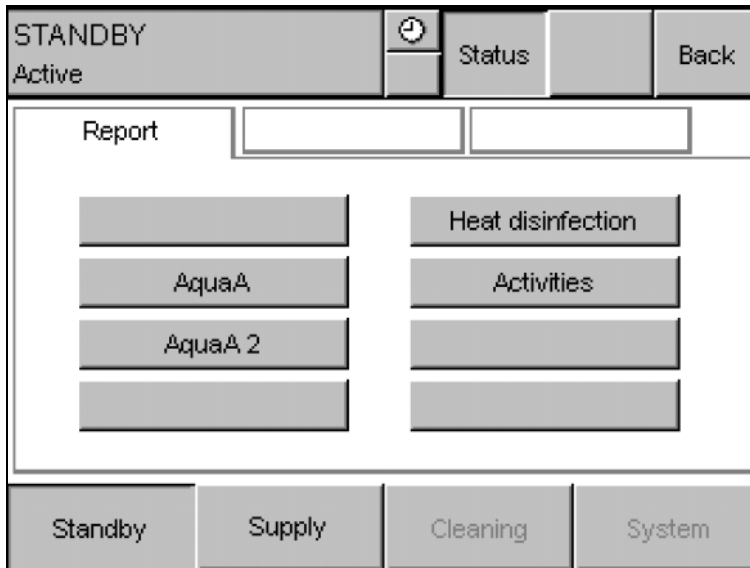

A report on the most recent activities of the **AquaA** can be displayed via the **Activities** menu option. This report shows the start time and start date of each activity.

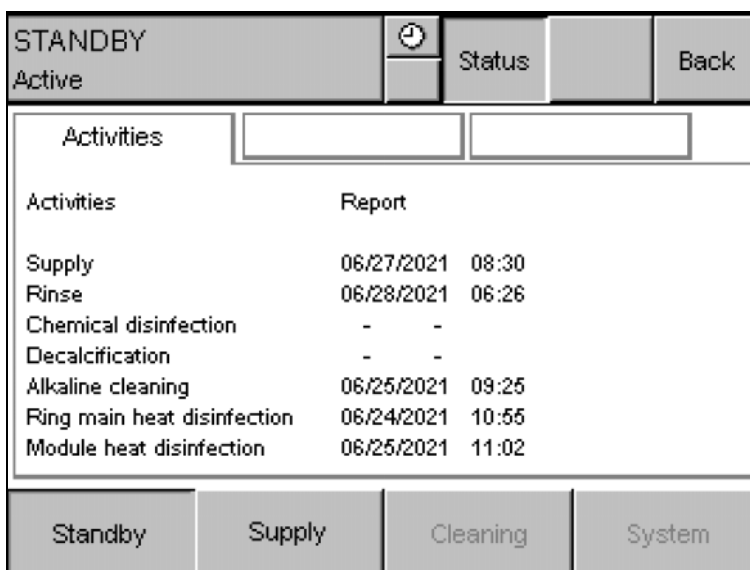

The following activities are included in this report:

- **SUPPLY**: Last start of **SUPPLY** mode
- **RINSE**: Last start of **RINSE** mode. This includes rinsing of the **AquaA** as well as the **RINSE-Water pretreatment**.
- **CHEMICAL DISINFECTION**: Last start of a chemical disinfection.
- **DECALCIFICATION**: Last start of a decalcification.
- **ALKALINE CLEANING**: Last start of an alkaline cleaning.
- **RING MAIN HEAT DISINFECTION**: Last start of a ring main heat disinfection. This activity is only displayed when using an **AquaHT**.
- **MODULE HEAT DISINFECTION**: Last start of a module heat disinfection. This activity is only displayed when using an **AquaHT**.

4.10.3 STATUS–Start/Stop

● **Menu structure–overview**

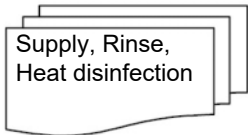

The current settings of the switching programs are displayed by pressing the **Start/Stop** button. After selecting this option, the **Autostart** and **Autostop** switching program settings are displayed.



Note

The **Start-Stop** times displayed for the **SUPPLY** mode do not include any temporary switching program changes.

Deviations in switching program operation (such as an extension or reduction of the time) may result in time differences (see chapter 4.5.8 on page 53).

4.10.3.1 Switching program–Supply

Three switching programs are shown in separate columns: Supply, Rinse and Heat disinfection.

STANDBY Active		⌚	Status	Back			
Supply		Rinse	Heat disinfection				
Start	Stop	Start	Stop	Start	Stop	Start	Stop
06:00	22:00	06:00	18:00	06:00	16:00	06:00	14:00
P1 Mon	<input checked="" type="checkbox"/>	P2 Mon	<input type="checkbox"/>	P3 Mon	<input type="checkbox"/>	P4 Mon	<input type="checkbox"/>
<input checked="" type="checkbox"/> Tue	<input type="checkbox"/>	<input checked="" type="checkbox"/> Tue	<input checked="" type="checkbox"/>	<input checked="" type="checkbox"/> Tue	<input type="checkbox"/>	<input type="checkbox"/> Tue	<input type="checkbox"/>
Wed	<input checked="" type="checkbox"/>	Wed	<input checked="" type="checkbox"/>	Wed	<input type="checkbox"/>	Wed	<input type="checkbox"/>
Thu	<input type="checkbox"/>	Thu	<input checked="" type="checkbox"/>	Thu	<input type="checkbox"/>	Thu	<input type="checkbox"/>
Fri	<input checked="" type="checkbox"/>	Fri	<input type="checkbox"/>	Fri	<input type="checkbox"/>	Fri	<input type="checkbox"/>
Sat	<input type="checkbox"/>	Sat	<input type="checkbox"/>	Sat	<input checked="" type="checkbox"/>	Sat	<input type="checkbox"/>
Sun	<input type="checkbox"/>	Sun	<input type="checkbox"/>	Sun	<input type="checkbox"/>	Sun	<input type="checkbox"/>
Standby		Supply		Cleaning		System	

The start and stop times for each program is shown in the first line. Below the times are two columns.

The left column (detailed view) shows the activation status of the first switching program, program **P1**.

The right column shows the activated weekdays.

Detailed view

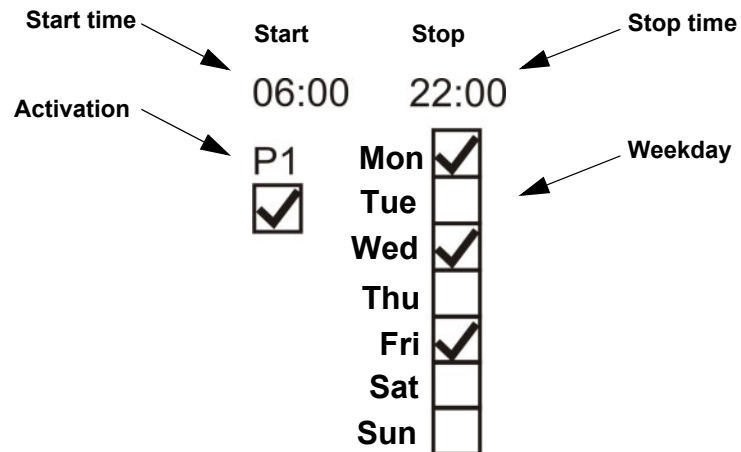

4.10.3.2 Switching program-Rinse

The settings for the interval rinse can be viewed by pressing the **Rinse** tab. The first screen shows the currently programmed interval.

The screenshot shows the 'Rinse' tab selected in the 'Rinse program time control' screen. The 'Cycle time' is set to 4 hours, and the 'individual' option is selected. The screen also shows 'Supply', 'Heat disinfection', and 'Status' tabs, and a 'Back' button. At the bottom, there are buttons for 'Standby', 'Supply', 'Cleaning', and 'System'.

The following screen shows the **Switching program-Rinse** information.

**Tip**

The scroll bar can be used to view the different pages.

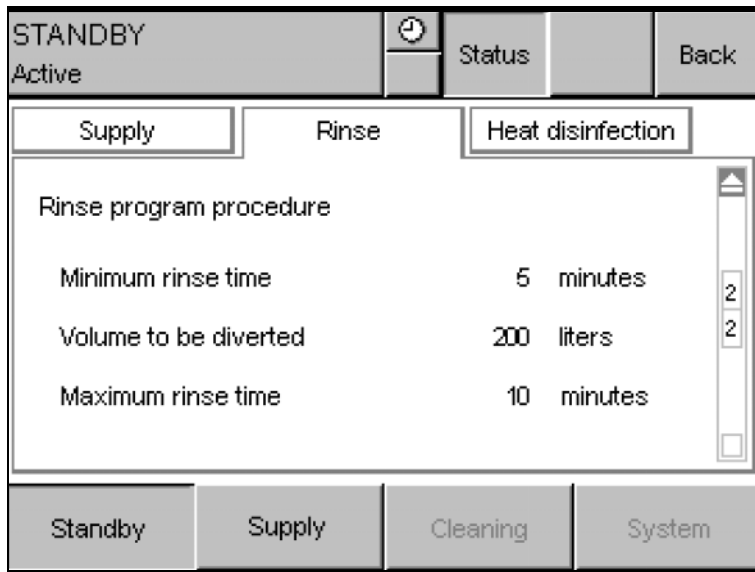

The minimum rinse time, the volume to be diverted and the maximum rinse time are displayed. The information displayed relates to both interval rinses and the manual rinsing program for the **AquaA** (see chapter 4.6 on page 54).

The water pretreatment rinse time is configured by the service technician (**System Technician** training) in the Service menu of the **AquaA**.

4.10.3.3 Switching program–Heat disinfection

STANDBY		⌚	Status	Back
Active				
Supply		Rinse		Heat disinfection
Start	Type	Start	Type	
20:00	Ring main	01:00	Module	
	weekly		every 2 weeks	
P1	Mon <input checked="" type="checkbox"/>	P2	Mon <input type="checkbox"/>	1 2
<input checked="" type="checkbox"/>	Tue <input type="checkbox"/>	<input checked="" type="checkbox"/>	Tue <input checked="" type="checkbox"/>	
	Wed <input checked="" type="checkbox"/>		Wed <input type="checkbox"/>	
	Thu <input type="checkbox"/>		Thu <input type="checkbox"/>	
	Fri <input checked="" type="checkbox"/>		Fri <input type="checkbox"/>	
	Sat <input type="checkbox"/>		Sat <input type="checkbox"/>	
	Sun <input type="checkbox"/>		Sun <input type="checkbox"/>	
Standby	Supply	Cleaning	System	

STANDBY		⌚	Status	Back
Active				
Supply		Rinse		Heat disinfection
Start	Type	Start	Type	
02:00	Module	01:40	Module	
	every 2 weeks		monthly	
P3	Mon <input type="checkbox"/>	P4	Mor <input type="checkbox"/>	2 2
<input checked="" type="checkbox"/>	Tue <input type="checkbox"/>	<input checked="" type="checkbox"/>	Tue <input type="checkbox"/>	
	Wed <input type="checkbox"/>		Wed <input type="checkbox"/>	
	Thu <input checked="" type="checkbox"/>		Thu <input type="checkbox"/>	
	Fri <input type="checkbox"/>		Fri <input type="checkbox"/>	
	Sat <input type="checkbox"/>		Sat <input type="checkbox"/>	
	Sun <input type="checkbox"/>		Sun <input checked="" type="checkbox"/>	
Standby	Supply	Cleaning	System	

The heat disinfection switching program settings can be displayed by selecting the **Heat disinfection** tab.

This screen shows the start time and type of the two switching programs, **P1** and **P2**.

The right column shows the activated weekdays. The left column shows the activation status of the first switching program, program **P1**.

The type of heat disinfection is shown in plain text above the right column. The activation interval of the switching program is shown below the start time and the type of heat disinfection.

The second screen shows switching programs **P3** and **P4**. As an example, this screen shows a 14-day and a monthly activation interval.

4.10.4 STATUS–System information

- **Menu structure–overview**

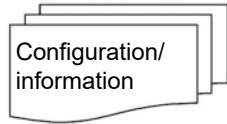

System information such as Configuration/Information are displayed as follows:

4.10.4.1 System information–device configuration

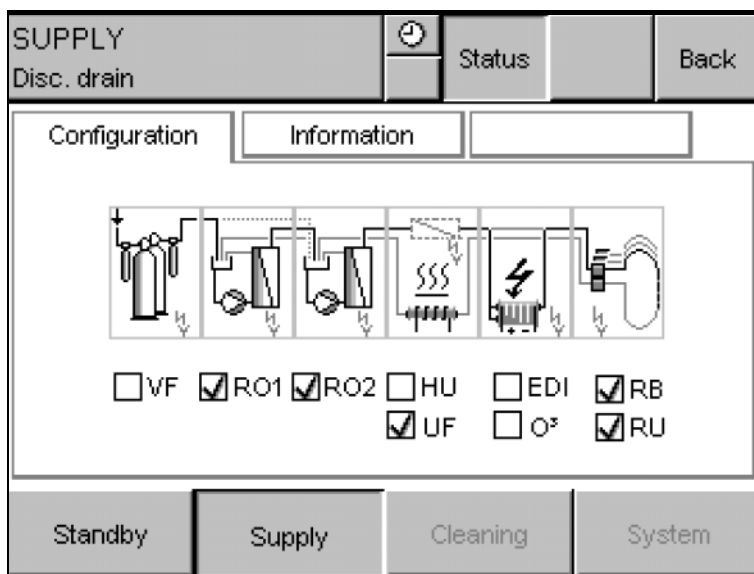

This screen shows the current configuration of the **AquaA** system.

4.10.4.2 STATUS System information–AquaA

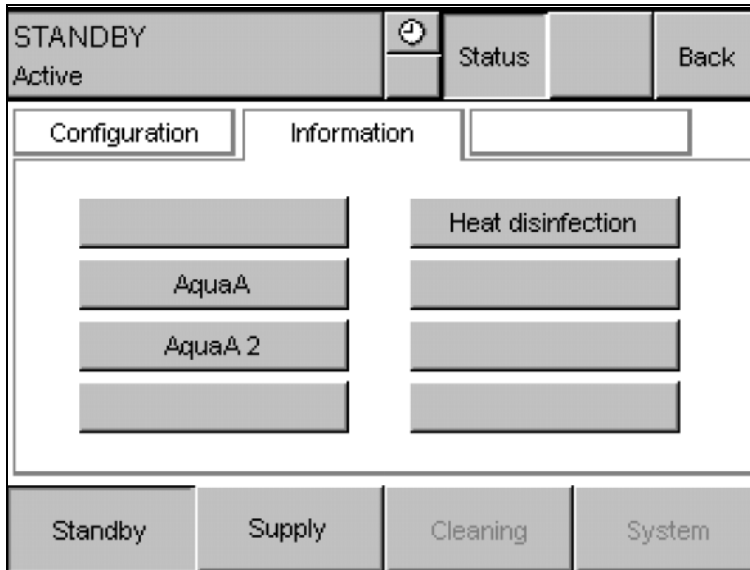

Select **AquaA** to display an information screen with the default settings of the **AquaA**.

The following data are displayed:

- **AquaA** serial number
- Last Technical Safety Check (TSC)
- Software version of the PLC control unit
- Software version of Display
- IP address of the display
- IP address of the PLC control unit
- IP address of the **AquaA**.

This network card is provided for connecting to a service PC.

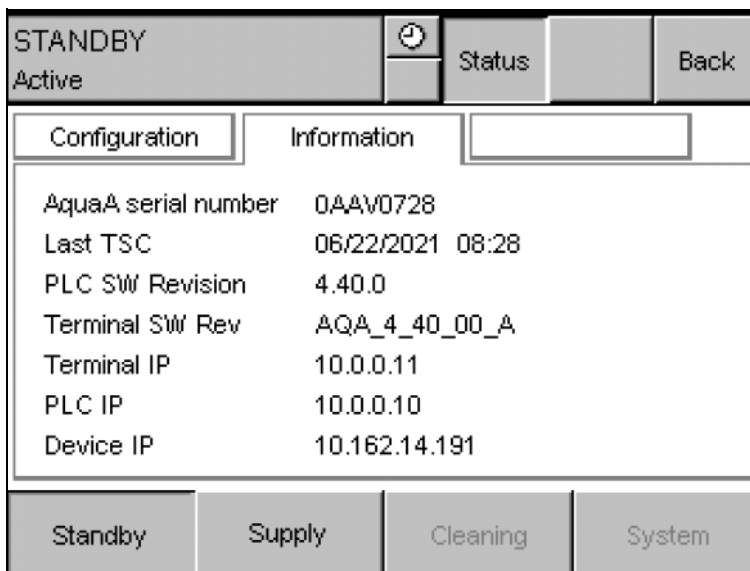

4.10.4.3 STATUS System information–AquaA2



Tip

The menu structure of the STATUS System information for the **AquaA2** is identical with the menu structure of the **AquaA**, and is operated via the display of the **AquaA**.

This information screen shows basic information about the **AquaA2**.

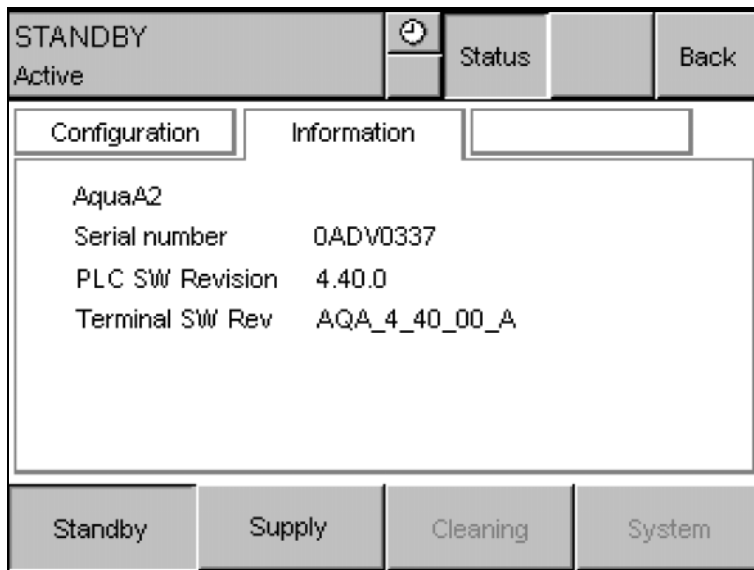

The following data are displayed:

- **AquaA2** serial number
- Software version of the **AquaA** control unit
- Software version of the **AquaA** display

4.10.4.4 STATUS System information–AquaHT



Tip

The menu structure of the STATUS information for the **AquaHT** is identical to the menu structure of the **AquaA**, and is operated using the **AquaA** display.

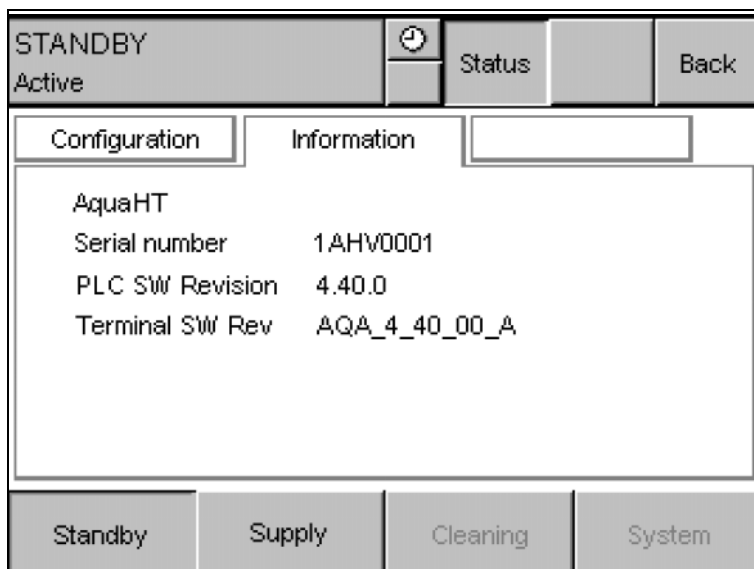

This information screen shows basic information about the **AquaHT**.

- **AquaHT** serial number
- Software version of the **AquaA** control unit
- Software version of the **AquaA** display

4.10.5 STATUS–Operating data

- **Menu structure–overview**

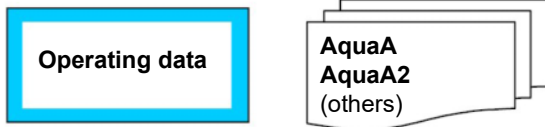

STATUS–Operating data displays information about the **AquaA**, **AquaA2** or **AquaHT**.

4.10.5.1 STATUS–Operating data–AquaA

- **Menu structure–overview AquaA**

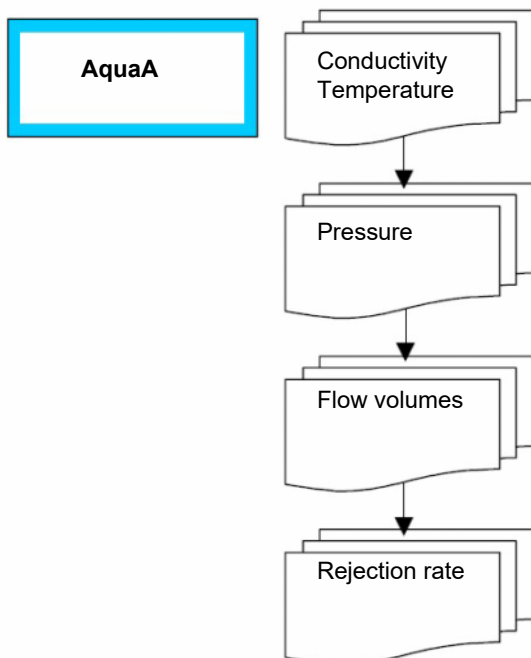

The **Operating data AquaA** information screen allows all required operating parameters for the device to be viewed using the scroll bar.

● **Operating data–Conductivity and temperature**

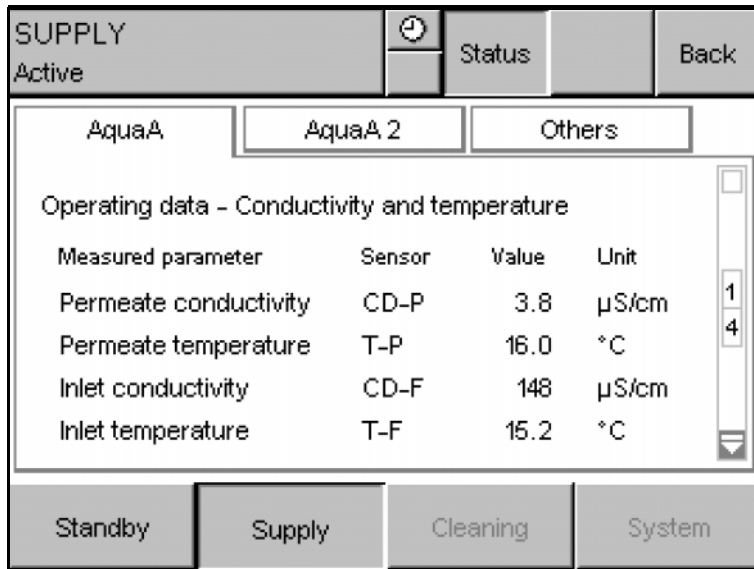

Operating data–Conductivity and temperature:

This screen shows the currently measured values for conductivity and temperature (see also Overview table).

Measured value	Sensor	Measuring range	Unit
Permeate conductivity (Dialysis water conductivity)	CD-P	0.0 to 2500.0	µS/cm
Permeate temperature (Dialysis water temperature)	T-P	0.0 to 115.0	°C
Inlet conductivity	CD-F	0.0 to 2500.0	µS/cm
Inlet temperature	T-F	0.0 to 115.0	°C

● **Operating data–Pressure**

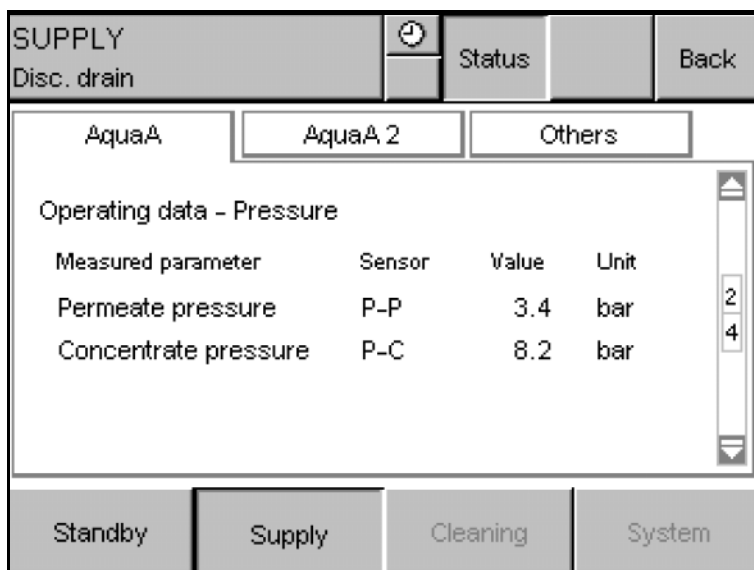

Operating data–Pressure:

This screen shows the currently measured pressure values (see also Overview table).

Measured value	Sensor	Measuring range	Unit
Permeate pressure (Dialysis water pressure)	P-P	0.0 to 10.0	bar
Concentrate pressure	P-C	0.0 to 20.0	bar

● Operating data–Flow volumes

Measured parameter	Sensor	Value	Unit
Feed flow	FL-F	10.5	L/min
Diversion	FL-C	0.0	L/min
Permeate consumption		8.5	L/min
Daily consumption		1581	liters

Operating data–Flow volumes:

This screen shows the currently measured flow volumes (see also Overview table).

In addition to this information, the current daily consumption is displayed.

Measured value	Sensor	Measuring range	Unit
Feed flow	FL-F	4.0 to 160.0	L/min
Diversion	FL-C	4.0 to 160.0	L/min
Permeate consumption	calculated	4.0 to 160.0	L/min
Daily consumption	---	0 to 999999	liters

● **Operating data–Efficiency, rejection rate**

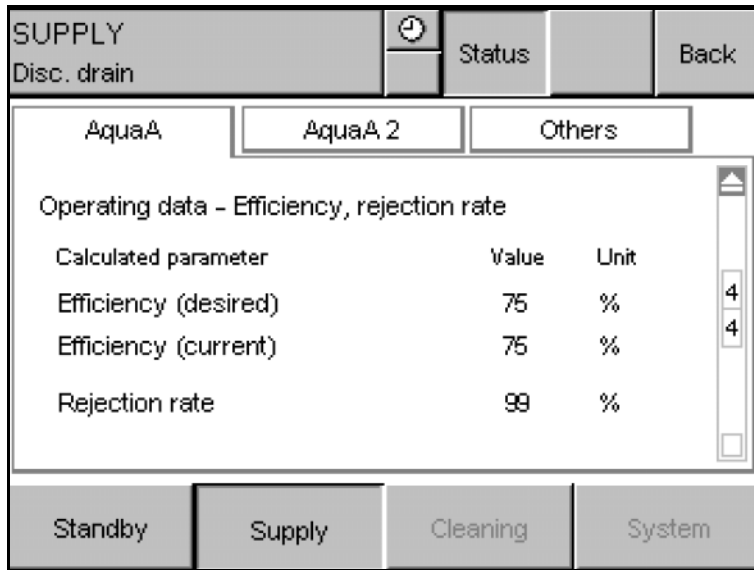

Operating data–Efficiency, rejection rate:

This screen shows the current efficiency and the rejection rate (see also Overview table).

Measured value	Sensor	Measuring range	Unit
Efficiency (desired)	–	50 to 85	%
Efficiency (current)	–	0 to 100	%
Rejection rate	calculated	0 to 100	%

- **Menu structure–overview AquaA2**

Overview Operating data

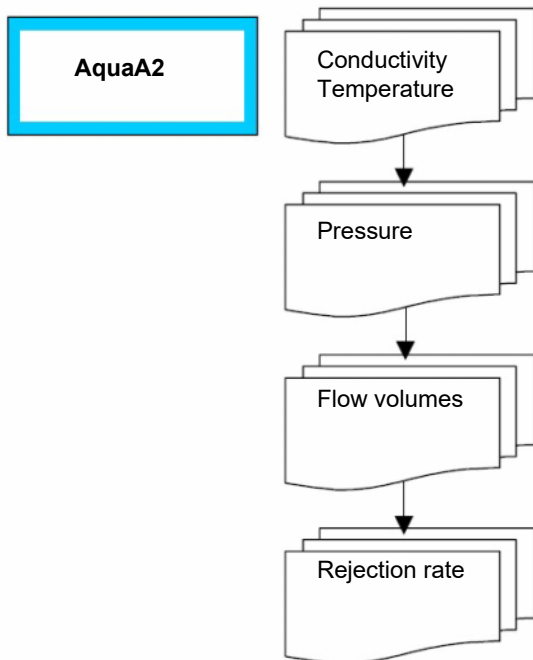

The **Operating data–Efficiency, rejection rate AquaA2** information screen allows all required operating parameters for the device to be viewed using the scroll bar.

4.10.5.2 STATUS–Operating data–AquaA2

- **Operating data–Conductivity and temperature–AquaA2**

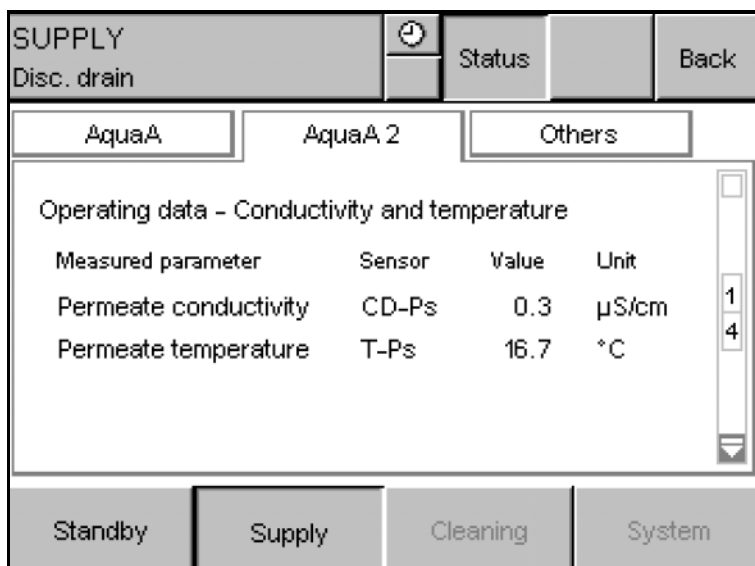

This screen shows the currently measured values for conductivity and temperature (see also Overview table).

Measured value	Sensor	Measuring range	Unit
Permeate conductivity (Dialysis water conductivity)	CD-Ps	0.0 to 2500	µS/cm
Permeate temperature (Dialysis water temperature)	T-Ps	0.0 to 115.0	°C

● **Operating data–Pressure–AquaA2**

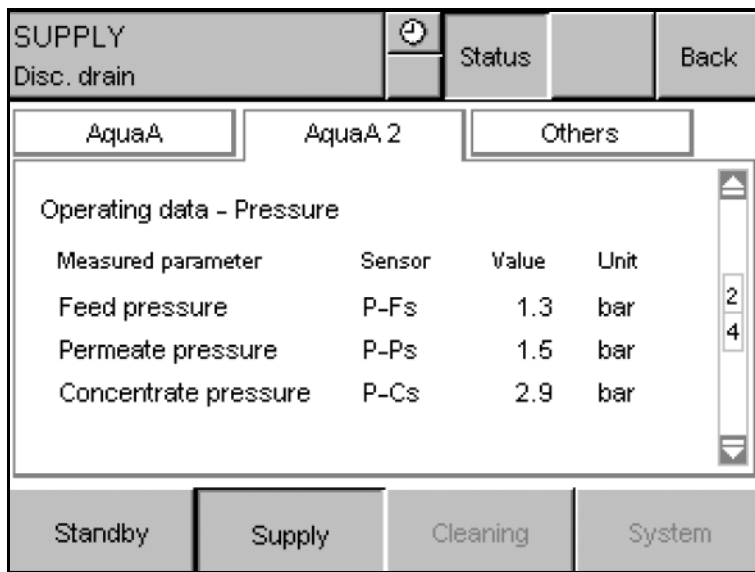

This screen shows the currently measured pressures (see also Overview table).

Measured value	Sensor	Measuring range	Unit
Feed pressure	P-Fs	0.0 to 10.0	bar
Permeate pressure (Dialysis water pressure)	P-Ps	0.0 to 10.0	bar
Concentrate pressure	P-Cs	0.0 to 20.0	bar

- **Operating data–Flow volumes–AquaA2**

SUPPLY		⌚	Status	Back
Disc. drain				
AquaA	AquaA 2	Others		
Operating data - Flow volumes				
Measured parameter	Sensor	Value	Unit	
Feed flow	FL-Fs	28.5	L/min	3
Diversion	FL-Cs	3.8	L/min	4
Daily consumption		1604	liters	
Standby	Supply	Cleaning	System	

This screen shows the currently measured flow volumes (see also Overview table).

In addition to this information, the current daily consumption is displayed.

Measured value	Sensor	Measuring range	Unit
Feed flow	FL-Fs	4.0 to 160.0	L/min
Diversion	FL-Cs	4.0 to 160.0	L/min
Daily consumption	–	0 to 999,999	liters

- **Operating data–Rejection rate–AquaA2**

SUPPLY		⌚	Status	Back
Disc. drain				
AquaA	AquaA 2	Others		
Operating data - Rejection rate				
Calculated parameter		Value	Unit	
Rejection rate		98.5	%	4
Standby	Supply	Cleaning	System	

This screen shows the current value of the rejection rate (see also Overview table).

Measured value	Sensor	Measuring range	Unit
Rejection rate	calculated	0 to 100	%

4.10.5.3 STATUS–Operating data–AquaHT

In the Operating data–Heat disinfection information screen, **Others** can be viewed using the tabs.

- **Operating data–Temperature**

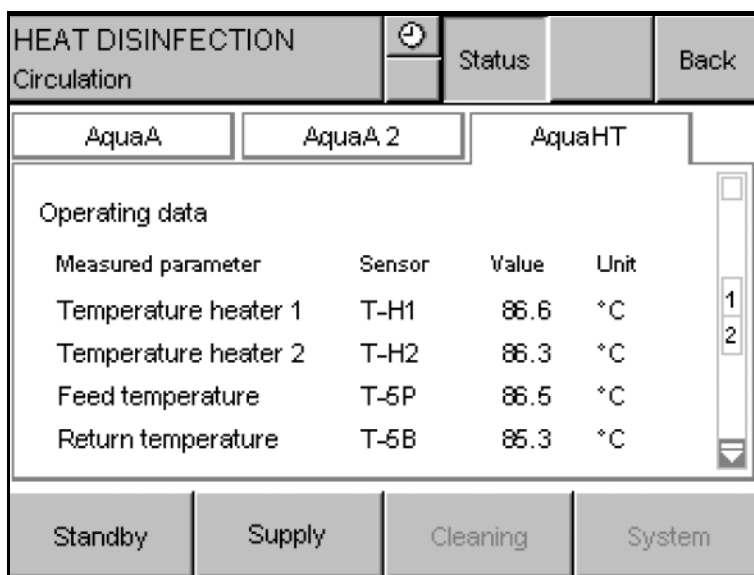

This screen shows the current temperatures.

Measured value	Sensor	Measuring range	Unit
Temperature heater 1	T-H1	0.0 to 115.0	°C
Temperature heater 2	T-H2	0.0 to 115.0	°C
Feed temperature	T-5P	0.0 to 115.0	°C
Return temperature	T-5B	0.0 to 115.0	°C

- **Operating data–Flow/volumes**

HEAT DISINFECTION		Status		Back
Circulation				
AquaA	AquaA 2	AquaHT		
Operating data				
Measured parameter	Sensor	Value	Unit	
Flow - heater 1	FL-H1	44.8	L/min	
Return flow	FL-B	46.5	L/min	
Tank volume		344	liters	
Standby	Supply	Cleaning	System	

This screen shows the current flows and tank volumes.

Measured value	Sensor	Measuring range	Unit
Flow - heater 1	FL-H1	4.0 to 160.0	L/min
Return flow	FL-B	4.0 to 160.0	L/min
Tank volume	–	0.0 to 380.0	liters

4.11 SETUP/SERVICE Menu

- Menu structure—overview

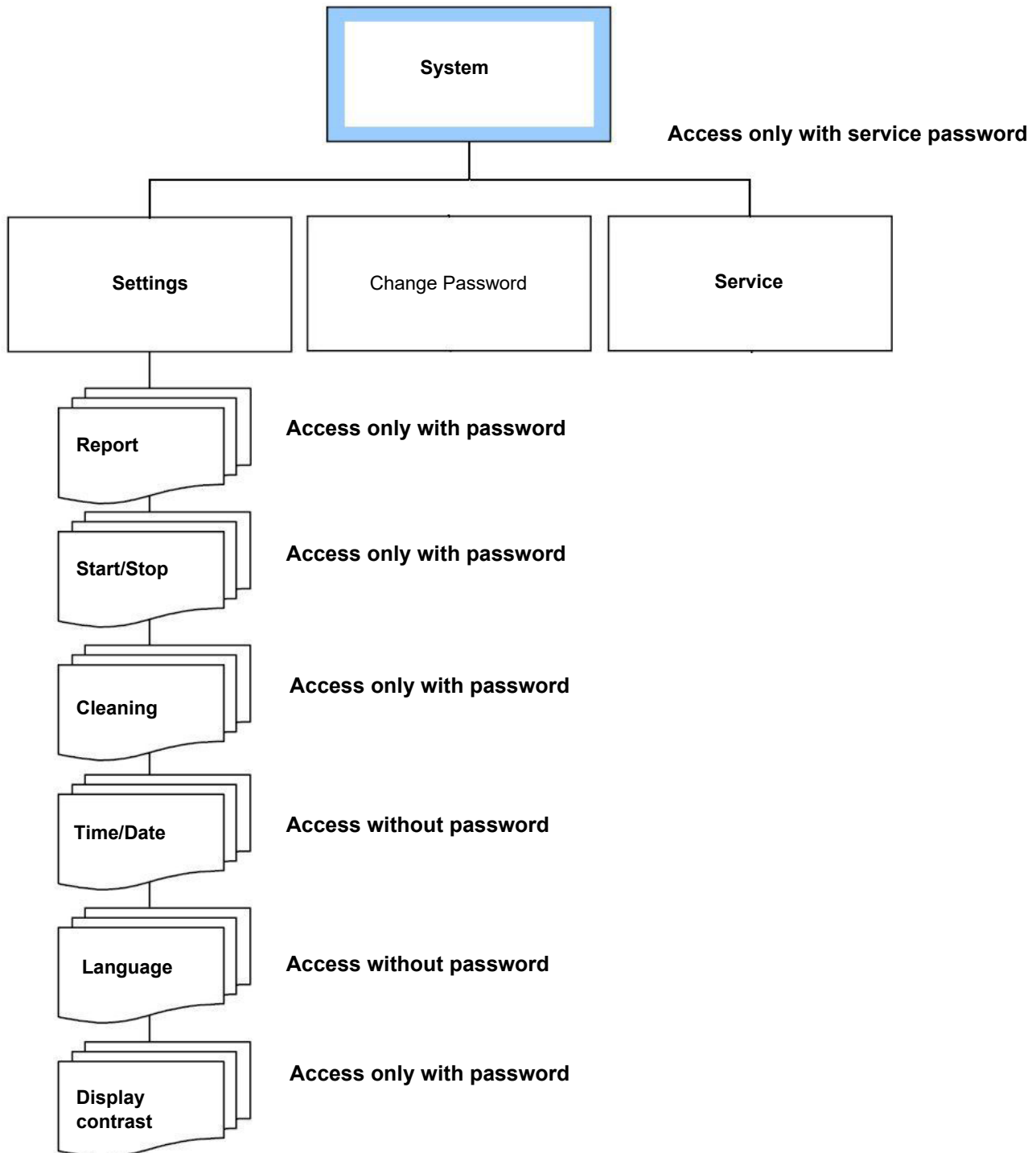

4.11.1 System menu

The **System** button opens the system menu.

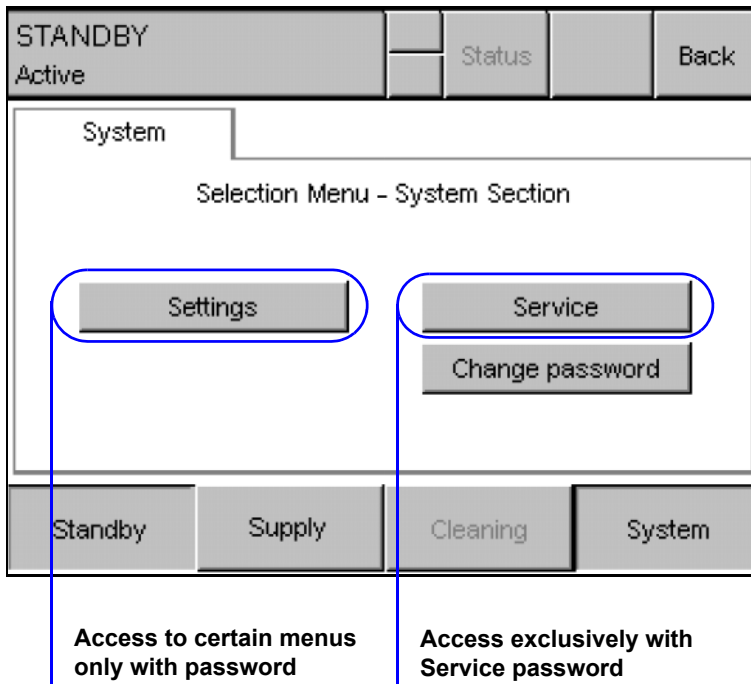

The **Settings** button opens the selection menu for settings which can be made by the operator.

The **Service** button opens the selection menu for the service. Access to this section is password-protected.

Change password opens the menu for changing the operator password. For more information (see chapter 4.13 on page 105).

4.11.2 General information on entering the password



Warning

Patient hazard

The password allows access to the service area of the control unit where parameters and values can be changed.

These changes have a direct influence on the operation of the **AquaA**.

The password is only intended for authorized personnel.

● **Overview of password access permissions**

For an overview of all password access permissions for the operator in operating modes and operating states (see chapter 4.2 on page 43).

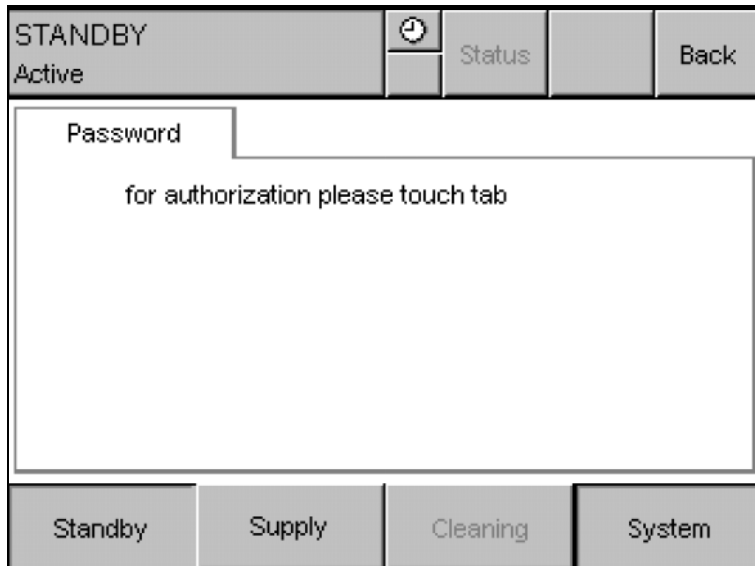

The **System** button opens the screen for entering the password.

To enter a password, press the area on the screen for authorization. The actual screen for entering the password is displayed.

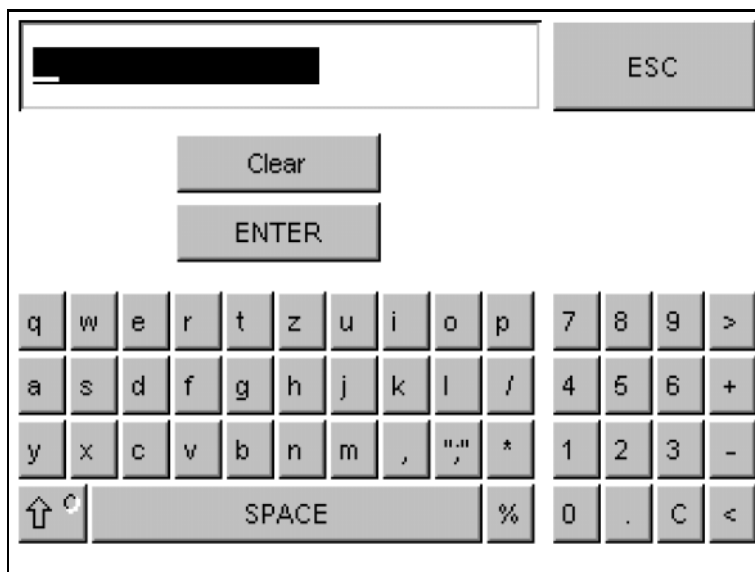

Access to the Service menu is restricted to service technicians.

Password required!



Tip

For further information on the password, please contact the authorized technician.

4.11.3 SYSTEM –Settings

● Menu structure–overview

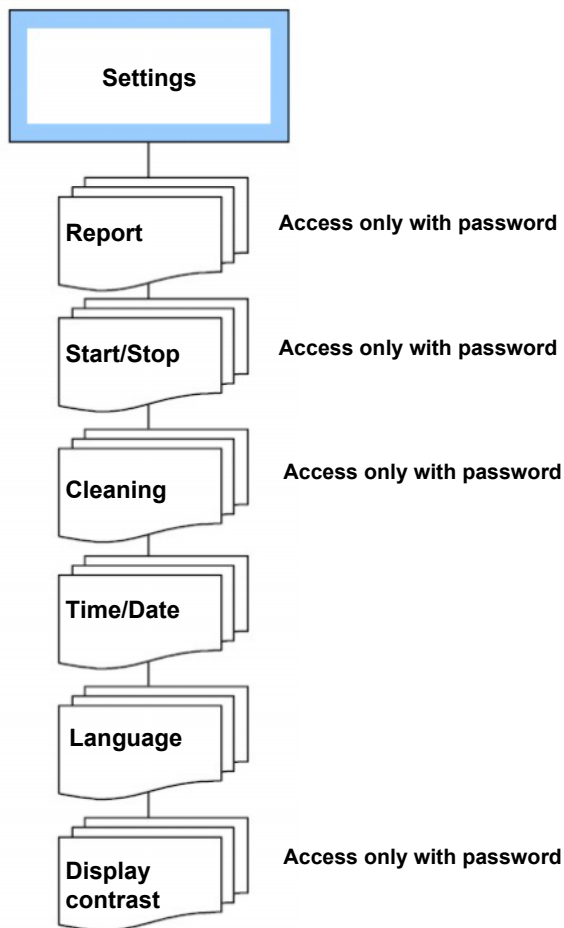

The **Settings** tab opens the following screen:

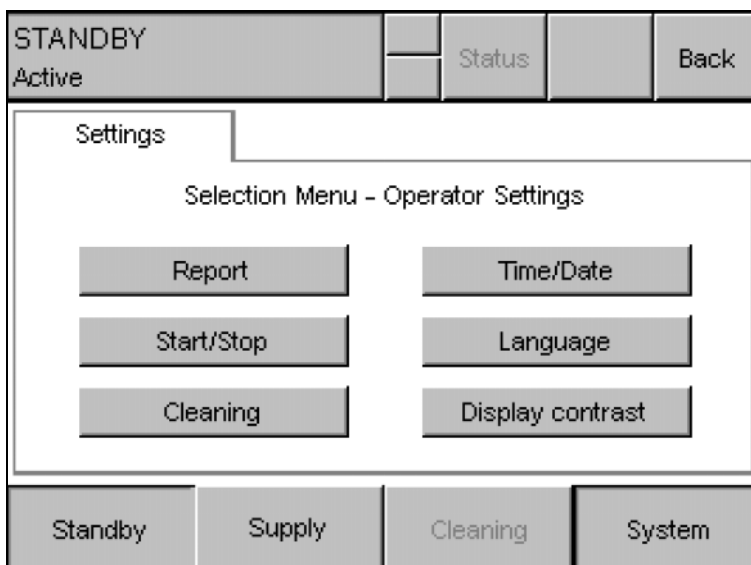

The following operator settings can be accessed:

- **Report**
- **Start/Stop**
- **Cleaning**
- **Time/Date**
- **Language**
- **Display contrast**

4.11.3.1 SETTINGS–Report (password-protected)

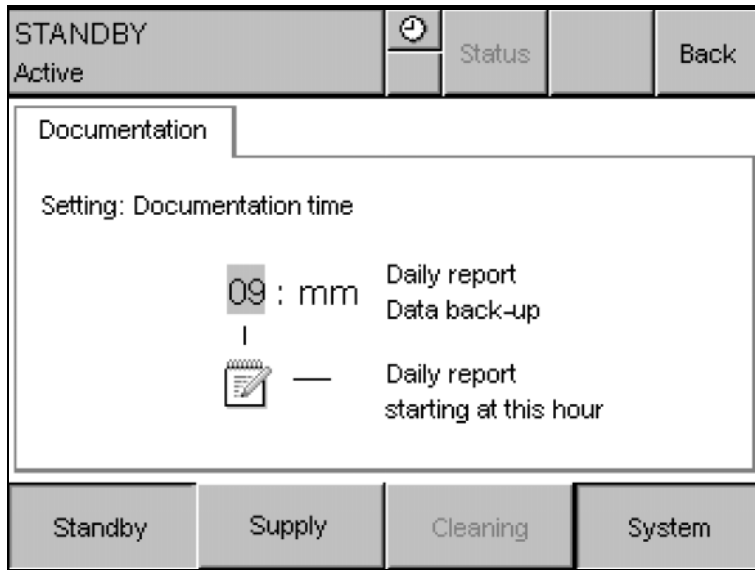

This menu option is provided to set the time for the creation of the daily report or the daily data backup.

Default setting: 9 a.m.



Note

Entries are only added to the daily report when **SUPPLY** mode is active.

4.11.3.2 SETTINGS–Switching program (password-protected)

The **Autostart** and **Autostop** programs (**Switching program-Supply**) are set in this menu option. **Autostart** is used to initiate a switch to **SUPPLY** mode. **Autostop** is used to initiate a switch to **STANDBY** mode.

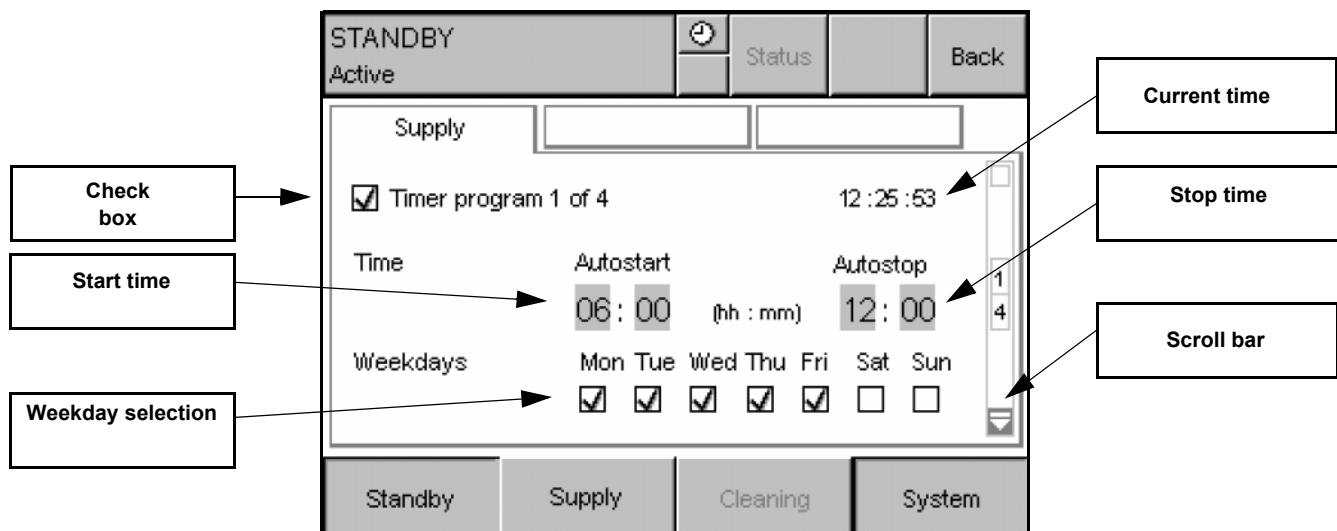

The **AquaA** has four switching programs to start the **SUPPLY** mode.

These four different programs can be accessed via the scroll bar on the right. Each of these programs can be programmed independently.

4.11.3.3 Programming the switching programs

- **Changing the autostop time once**

To change the autostop time only once, follow the description in (see chapter 4.5.8 on page 53).

- **Programming Switching program in 7 steps:**

Step 1

To make changes in the switching program, the check box **Switching program deactivated** must be checked.



Tip

- : Switching program activated
- : Switching program deactivated

Step 2

Enter the minute for the start.

Step 3

Enter the hour for the start.

Step 4

Enter the minute for the stop.

Step 5

Enter the hour for the stop.



Note

The hours for the start and stop time must not match.

If the hour for start and stop are the same, the switching program does not start (e.g., switching program 1: 5:15 to 5:10).

This also applies when using two switching programs with day overflow.

Step 6

Select the weekdays on which the switching program is to be activated.

Step 7

To complete changes in the switching program, check the **Switching program activated** check box.



Tip

- : Switching program activated
- : Switching program deactivated

- **Programming example for extension to the next day:**

Dialysis start Monday at 05:30 a.m.

Dialysis end Tuesday at 06:10 a.m.

● **Programming overlapping switching programs:**

Two switching programs must be programmed:

Switching program 1: Mon. START 5:30 a.m. STOP 4:00 a.m.

Switching program 2: Tue. START 4:00 a.m. STOP 5:00 p.m.

Explanation

Switching program 1 starts on Monday at 5:30 a.m. As the stop time is earlier than the start time, the **AquaA** would stop on Tuesday morning at 04.00 a.m. But since the second switching program is active on Tuesday at 4:00 a.m., the **AquaA** continues operating until the stop time of the second switching program.

The **AquaA** will stop on Tuesday at 5 p.m.. The start of one switching program always has priority over the stop of another switching program.

4.11.3.4 SETTINGS–Cleaning (password-protected)

● **Rinse-Switching program**

The **AquaA** has a rinse program. To program the rinse interval, select the menu option Cleaning.

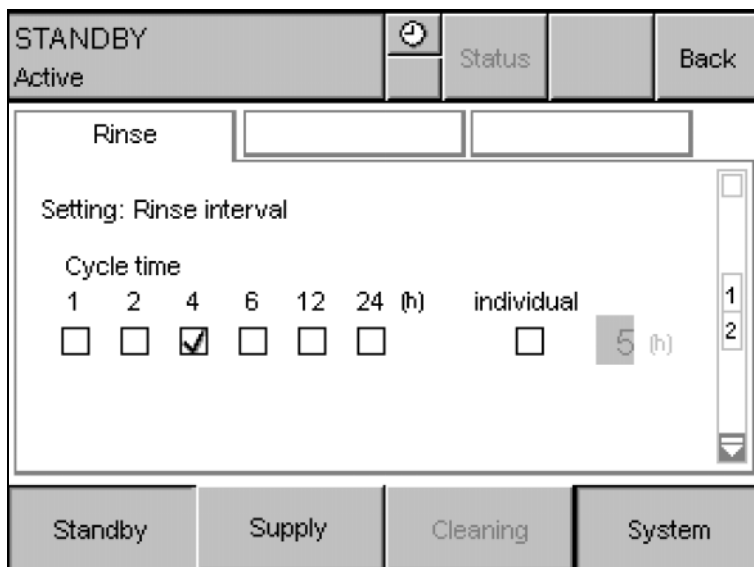

The rinse interval can be programmed with fixed intervals (**1, 2, 4, 6, 12, 24 hours**) and a freely selectable interval.

The individual rinse interval can be selected within a range of **1 to 72 hours**.

Default setting: 4 hours

STANDBY Active		Status	Back
Rinse	<input type="text"/>	<input type="text"/>	
Setting: Rinse mode			
Minimum rinse time	10	minutes	<input type="text" value="2"/>
Volume to be diverted	100	liters	<input type="text" value="2"/>
Maximum rinse time	15	minutes	<input type="text"/>
Standby	Supply	Cleaning	System

Use the scroll bar to access the rinse parameter screen. The information displayed relates to both interval rinses and the manual rinsing program for the **AquaA** (see chapter 4.6 on page 54).

The water pretreatment rinse time is configured by the service technician (**System Technician** training) in the Service menu of the **AquaA**.

Parameter	Adjustment range	Default setting
Minimum rinse time	5 to 30 min	10 Minutes
Volume to be diverted	0 to 500	0 Liters
Maximum rinse time	15 to 45 min	45 Minutes



Note

The maximum time must be longer than the minimum time and it must be ensured that the volume to be diverted can be diverted within the maximum time!

Otherwise a warning will be displayed.

● Recommended rinse volume for reverse osmosis systems

To keep the formation of biofilm during downtime of the system as low as possible and to prevent high microbial counts at the start of dialysis after the reverse osmosis system is switched on, regular rinsing of the device is recommended.



Note

It is recommended to rinse the reverse osmosis system **every 4 hours**.

The selected rinse volume should be no less than the dialysis water volume of the system.

Reverse osmosis system rinse volume

- **AquaA 900H/1000:** 4 L + 0.4 x length of the ring main(s)
- **AquaA 1800H/2000:** 6 L + 0.4 x length of the ring main(s)
- **AquaA 2700H/3000:** 8 L + 0.4 x length of the ring main(s)

Example calculation for an AquaA

- **AquaA 3600H/4000:** 10 L + 0.4 x length of the ring main(s)

AquaA 2700H/3000 with 250 m ring main:

- 8 L + (0.4 x 250) = 8 L + 100 L = 108 L

The rinse volume to be programmed should be at least 108 liters.

Example calculation for an AquaA2

- If an **AquaA2** is connected, the calculated rinse volumes of the **AquaA** must be increased by the factor 2.

Example calculation for an AquaHT

- For a connected **AquaHT**, an additional 2.5 L must be added to the rinse volume.



Note

Rinsing can be performed with or without discarding the dialysis water. If “0 liters” is entered, dialysis water will not be discarded, and will instead only be circulated.

For this option, the minimum rinse volume must however be previously adapted to the calculated total volume. The minimum time is calculated on the basis of the system capacity and the total volume to be replaced.

AquaA device output:

- **AquaA 900H/1000:** device output 6 L/min
- **AquaA 1800H/2000:** device output 13 L/min
- **AquaA 2700H/3000:** device output 20 L/min
- **AquaA 3600H/4000:** device output 26 L/min

● **Calculation example for an AquaA 2700H + AquaA2 + AquaHT and a ring main length of 300 m:**

Based on the above calculation example, **134 L** of dialysis water must be replaced.

Rinse time = (134 L) / (20 L/min) = 6.7 minutes

- Rounded up, this equals a minimum rinse time of **10 minutes**.
- As an alternative, consult the table. When doing so, round up the volume to be diverted to the next-highest value.

AquaA				
Vol- ume to be di- vert- ed	900H/1000	1800H/2000	2700H/3000	3600H/4000
	6 L/min	13 L/min	20 L/min	26 L/min
50 L	10 min	5 min	5 min	5 min
100 L	20 min	10 min	5 min	5 min
150 L	25 min	10 min	10 min	5 min

AquaA				
Volume to be diverted	900H/1000	1800H/2000	2700H/3000	3600H/4000
	6 L/min	13 L/min	20 L/min	26 L/min
200 L	30 min	15 min	10 min	10 min
250 L		20 min	15 min	10 min
300 L		25 min	15 min	10 min
350 L		30 min	20 min	15 min
400 L		20 min	15 min	10 min
450 L			25 min	15 min
500 L			25 min	20 min
550 L			30 min	20 min
600 L			30 min	25 min
650 L			30 min	25 min
700 L				30 min



Note

The rinse cycles can be extended, depending on the results of the microbiological analysis. Rinsing by the reverse osmosis system alone will never ensure a microbiologically safe condition.

4.11.3.5 SETTINGS–Time/Date

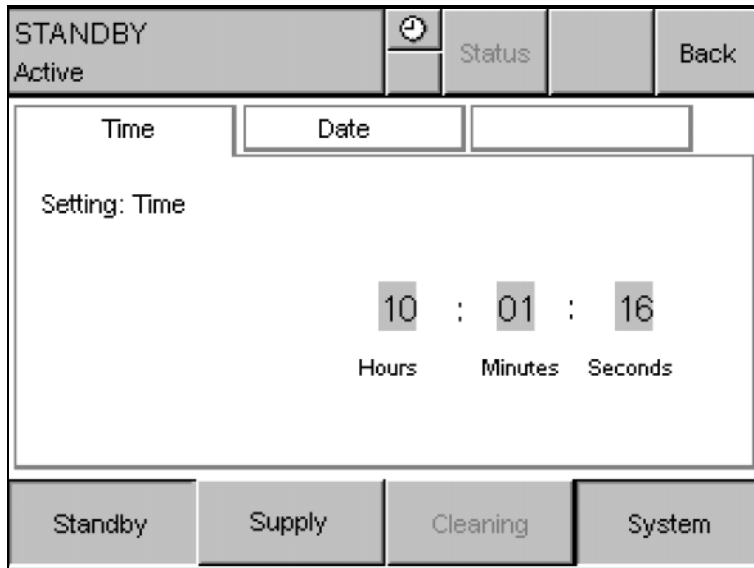

This menu is provided to set the time.

The data entered are automatically synchronized with the control settings.

The automatic change from daylight savings time to standard time and vice versa is carried out according to the regulations for Central Europe.

The automatic change can only be deactivated by an authorized service technician.

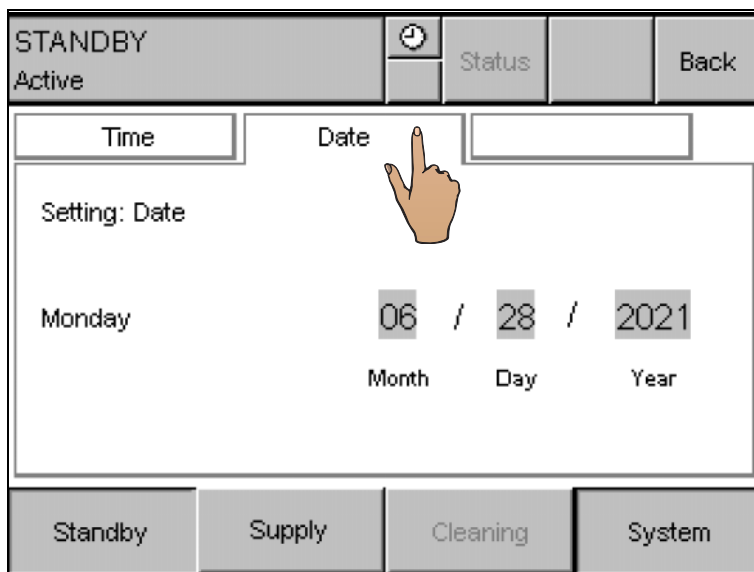

This menu is provided to set the date.

The data entered are automatically synchronized with the control settings.

4.11.3.6 SETTINGS–Language

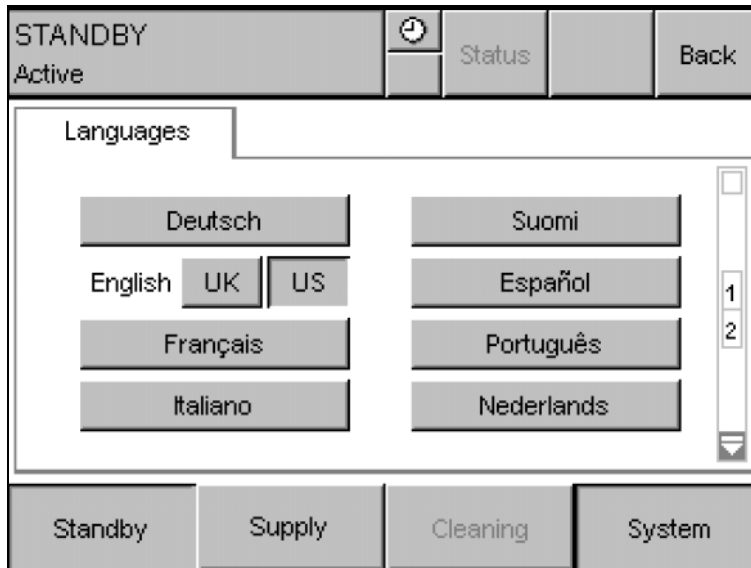

This menu option permits selection of the desired language from the installed languages.

When switching to US English, the date display and reports change to the following:

Month/day/year

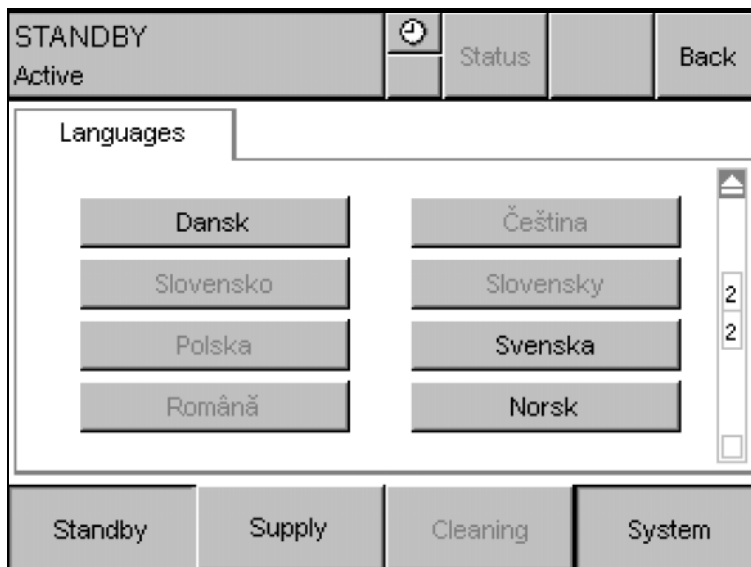

This menu option permits selection of other languages.

4.11.3.7 SETTINGS–Display contrast (password-protected)

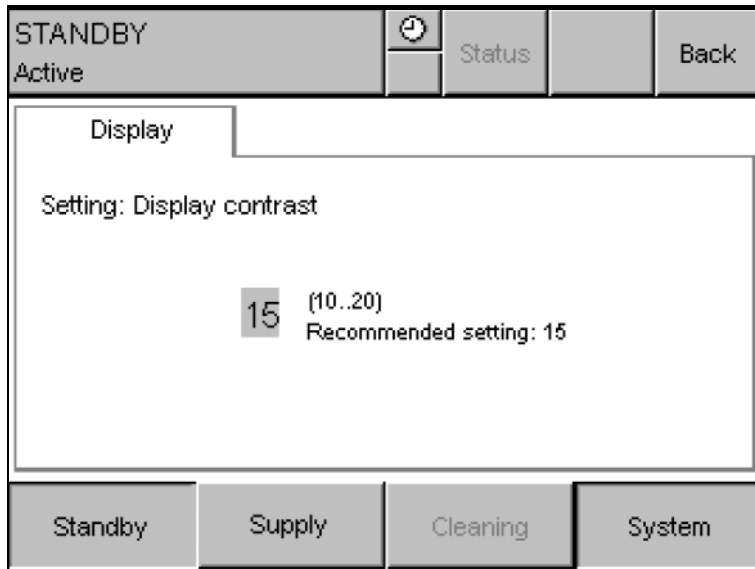

This menu option permits an adjustment of the display contrast to match the local lighting conditions.

Indication of the contrast range:

The contrast settings can be adjusted within the range of **10 to 20 units**.



Tip

A contrast setting of **15** is recommended.

4.12 SYSTEM–Service (only with password)

4.12.1 Access with password



Tip

The **SYSTEM Service** submenus cannot be accessed without a password.

This is reserved for the technical service.

4.13 Change password

STANDBY Active		Status		Back
Password				
Change password				
Old password		<input type="text"/>		
Standby	Supply	Cleaning	System	

In this menu the password for the areas with access protection can be changed.

- To change the password, please follow the steps below.

- 1. Enter your current password in the **Old password** field.
 - If the input is correct, the **New password** and **Confirm new password** fields will be displayed.
 - If the password is entered incorrectly or is unknown, an **Invalid password** message appears.

STANDBY Active		Status		Back
Password				
Change password				
Old password		<input type="text"/>		
Invalid password				Confirm
Standby	Supply	Cleaning	System	

The **Invalid password** message must be confirmed with the **Confirm** button. After confirmation the message is deleted and the old password may be reentered.

- 2. Enter the new password in the **New password** field.

The new password must meet the following minimum complexity:

- Do not repeat the password from the **Old password** field into the **New password** field.
- At least 10 characters (max. 11 characters can be used)
- No consecutive numbers (e.g., 123456789)
- At least one letter character
- At least one number
- At least one special character supported by the device (+ - % * . /)
- No dictionary passwords (e.g., password, Password1, ILoveYou, Pass123 etc.)

- 3. Enter the new password again in the **Confirm new password** field.

The correct change of the password is completed when no message appears in the window.

● 4. Invalid entry: Password unchanged

STANDBY		Status		Back
Active				
<div style="border: 1px solid black; padding: 5px;"> <p>Password</p> <p>Change password</p> <p>Old password <input type="password"/></p> <p>New password <input type="password"/></p> <p>Confirm new password <input type="password"/></p> <p>Invalid entry: Password unchanged <input type="button" value="Confirm"/></p> </div>				
Standby	Supply	Cleaning	System	

The message **Invalid entry: Password unchanged** is displayed, in case:

- The password in **New password** field differs from the password in **Confirm new password** field.
- The password in **New password** field is the same as the password in **Old password** field.
- Before entering the new password again, the message **Invalid entry: Password unchanged** must be confirmed with the **Confirm** button.

After confirmation, the message is deleted and a new entry is possible.

5 Alarms

5.1 Messages

5.1.1 Alarm message types

The alarm messages of the **AquaA** reverse osmosis system comprise in plain text:

- Date
- Time
- Error code
- Type of alarm message
- Operating state

Date and time indicate when the alarm was generated.

A new alarm message will be displayed immediately. The alarm message is confirmed by pressing the **Confirm** button.

Current alarm messages are displayed under **StatusMessages**. The alarm messages are not deleted automatically until they have been confirmed and the problem has been corrected.

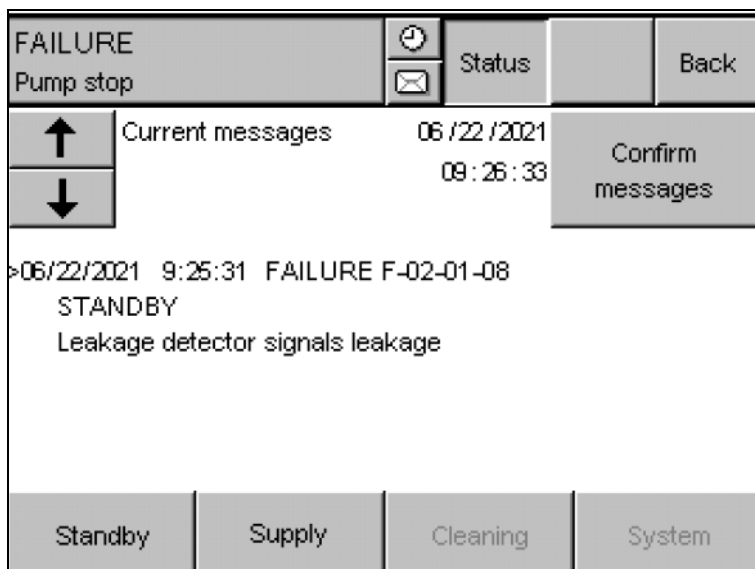

As soon as an alarm message has occurred, the control unit will automatically display the **Current messages** screen.

- Press the **Confirm messages** button to confirm the error and exit the screen.

Self-confirming alarms

Alarm messages may automatically confirm themselves and therefore only be visible temporarily. In the case of self-confirming alarm messages, the cause is no longer visible.

These alarm messages are marked with "*" in the following chapters.

● **Confirming alarms**

Confirm an alarm using the **Confirm** button. The alarm does not go off again if the alarm condition is still pending.

The current messages are displayed under **StatusMessages**. The messages will be deleted automatically after the message has been confirmed and the problem causing the message has been corrected.

The alarms can be transmitted to the patient treatment area using the Visual LED Indicator.

5.2 Contact details for the service department

The phone numbers to contact Fresenius Medical Care are listed in the Addresses chapter (see chapter 2.20 on page 31).

Should you make use of this service, please describe the error which occurred as precisely as possible (by telephone, if necessary) to help the technician analyze the problem. The following information should be available:

- Current operating data of the **AquaA** reverse osmosis system and other options.
- The number, kind, and type of components connected upstream and downstream.
- The error code on the display with date and time.

Format of the message:

[dd.mm.yy], time [hh.mm.ss], error code [X-XX-XX-XX], operating mode [], message text

5.3 Alarm description

5.3.1 Identification of the error code

F	01	01	01	
F				Identifier F – Error, failure W – Warning, warning condition
	01			Category 01 – System and hardware problem 02 – Procedure (e.g., violation of alarm limits) 03 – Preparation (e.g., start condition not fulfilled) 04 – Start test and test routine
		01		System 00 – Water pretreatment 01 – AquaA 02 – AquaA2 03 – Reserved 04 – AquaHT
			01	Message number 01 to 99 Identification of the number of FAILURE or WARNING

5.3.1.1 Significance of a fault, failure

Advises the operator that a persistent fault or failure can result in damage to the reverse osmosis system. Device faults or failure can result in consequences for the patient. The reverse osmosis system may continue to operate but is restricted in terms of its functions.

5.3.1.2 Significance of a warning, warning condition





Advises the operator that a persistent warning or warning condition can impair the normal operation of the reverse osmosis system. Restrictions may occur as a result of a persistent warning or warning condition. The reverse osmosis system may continue to operate but is restricted in terms of its functions.





5.4 Error category 01–system and hardware problems

The following tables list all errors which might occur when operating the system.

As some messages are identical except for certain criteria, these have been combined into groups. The errors are classified in categories of 01 to 03.





An error code marked with „*“ denotes a self-confirming message.







Error code	Visual indicator	Messages	Cause	Action required
F-01-01-01	Signal: red 	FAILURE: <i>Replace terminal battery</i>	– Insufficient display battery capacity	➤ Contact the service department
F-01-01-02	Signal: red 	FAILURE: <i>Overvoltage</i>	– Excess voltage at the operating unit. – This message is automatically cleared once the specified supply voltage has been reached.	➤ Check display power supply ➤ Contact the service department
F-01-01-03	Signal: red 	FAILURE: <i>FATAL ERROR</i> <i>Code: , Subcode:</i>	– This message is generated by the operating system of the terminal if proper operation can not be continued due to lack of security.	To reproduce the problem which occurred, the code and subcode as well as the software versions of the operating system and the user interface must be known. ➤ Contact the service department
F-01-01-04	Signal: red 	FAILURE: <i>COMMUNICATION ERROR</i> <i>Code: , Subcode:</i>	– Protocol and interface error	To reproduce the problem which occurred, the code and subcode as well as the software versions of the operating system and the user interface must be known. ➤ Contact the service department
F-01-01-05	Signal: red 	FAILURE: <i>I/O-Bus</i>	– BUS system connection interrupted – BUS component defective	➤ Contact the service department









Error code	Visual indicator	Messages	Cause	Action required
F-01-01-06	Signal: red 	FAILURE: <i>Control panel</i>	<ul style="list-style-type: none"> – Connection between display and control unit interrupted or defective. 	➤ Contact the service department
F-01-01-07	Signal: red 	FAILURE: <i>Communication (measuring transducer)</i>	<ul style="list-style-type: none"> – Communication problem from/to measuring transducer B4 – Measuring transducer B4 defective – Serial connection line COM1 defective 	➤ Contact the service department
F-01-01-08	Signal: red 	FAILURE: <i>Measuring transducer (ADC)</i>	<ul style="list-style-type: none"> – Reference measurement of test voltage (1.0 V_{DC}) failed – Measuring transducer B4 defective – Serial connection line COM1 defective – Digital output terminal A13 defective – Line connection between measuring transducer B4 and analog output terminal A13 defective 	➤ Contact the service department
W-01-01-01*	Signal: yellow 	WARNING: <i>Control panel, Screen change problem</i>	<ul style="list-style-type: none"> – The change of the screen on the display has not been processed within the defined time. 	➤ Contact the service department
W-01-01-03*	Signal: yellow 	WARNING: <i>Communication problem (ADS)</i>	<ul style="list-style-type: none"> – Connection problem between the AquaA reverse osmosis system and the connected partner system. – The partner system is switched off. – The network connection between the systems is defective or disconnected. 	➤ Contact the service department







5.5 Error category 02–violation of alarm limits



An error code marked with „*“ denotes a self-confirming message.

Error code	Visual indicator	Messages	Cause	Action required
F-02-01-01	Signal: red 	FAILURE: <i>Permeate cond. alarm limit exceeded</i>	<ul style="list-style-type: none"> – The dialysis water conductivity has exceeded the specified alarm limit. – Conductivity sensor CD-P defective – Measuring transducer B4 defective 	<p>This failure is confirmed automatically when the value drops below the alarm limit. The message will continue to be shown on the display, however.</p> <p>➤ Contact the service department</p>
F-02-01-02	Signal: red 	FAILURE: <i>Permeate temp. alarm limit exceeded</i>	<ul style="list-style-type: none"> – The dialysis water temperature has exceeded the specified alarm limit. – Conductivity sensor CD-P defective – Measuring transducer B4 defective 	<p>This failure is confirmed automatically when the value drops below the alarm limit. The message will continue to be shown on the display, however.</p> <p>➤ Contact the service department</p>
F-02-01-03	Signal: red 	FAILURE: <i>Permeate press. alarm limit exceeded</i>	<ul style="list-style-type: none"> – The dialysis water pressure has exceeded the specified alarm limit. – Pressure sensor P-P defective – Measuring transducer B4 defective 	<p>➤ Contact the service department</p>
F-02-01-04	Signal: red 	FAILURE: <i>Conc. pressure alarm limit exceeded</i>	<ul style="list-style-type: none"> – The concentrate pressure has exceeded the specified alarm limit. – Pressure sensor P-C defective – Measuring transducer B4 defective 	<p>➤ Contact the service department</p>
F-02-01-05	Signal: red 	FAILURE: <i>run-dry protection, pump stop</i>	<ul style="list-style-type: none"> – The level in the break tank has dropped to NIV1. – Water inlet pressure or flow too low 	<p>➤ Check water supply</p> <p>This failure is confirmed automatically when the level has risen to NIV2. The message will continue to be shown on the display, however.</p> <p>➤ Contact the service department</p>

Error code	Visual indicator	Messages	Cause	Action required
F-02-01-06	Signal: red 	FAILURE: <i>Fill level dropped - leakage</i>	<ul style="list-style-type: none"> – During disinfection, the level has dropped to NIV2. – Message indicating unauthorized water consumption during disinfection. 	➤ Contact the service department
F-02-01-07	Signal: red 	FAILURE: <i>Disinfection connector removed</i>	<ul style="list-style-type: none"> – Disinfectant connector disconnected 	➤ Connect the disinfectant connector to the appropriate connection port.
F-02-01-08	Signal: red 	FAILURE: <i>Leakage detector signals leakage</i>	<ul style="list-style-type: none"> – Indication of water leakage from the connected leakage sensor 	<ul style="list-style-type: none"> ➤ Check all water-carrying lines and connections. ➤ Contact the service department
F-02-01-09	Signal: red 	FAILURE: <i>External leakage detector signals leakage</i>	<ul style="list-style-type: none"> – Disconnected line between AquaA and external leakage detector – Leakage signaled by the external leakage detector (e.g. AquaDETECTOR) – No leakage detector connected 	<ul style="list-style-type: none"> ➤ Check leakage detector and lines. ➤ Contact the service department
F-02-01-10	Signal: red 	FAILURE: <i>External failure</i>	<ul style="list-style-type: none"> – Digital error message input activated from external source 	<ul style="list-style-type: none"> ➤ Check the status of connected external systems ➤ Contact the service department
W-02-01-01	Signal: yellow 	WARNING: <i>Permeate cond. alarm limit exceeded</i>	<ul style="list-style-type: none"> – The dialysis water conductivity has exceeded the specified alarm limit. – Conductivity sensor CD-P defective – Measuring transducer B4 defective 	➤ Contact the service department
W-02-01-02	Signal: yellow 	WARNING: <i>Inlet temperature too high</i>	<ul style="list-style-type: none"> – The inlet temperature has exceeded the specified alarm limit. – Conductivity sensor CD-F defective – Measuring transducer B4 defective 	➤ Contact the service department







Error code	Visual indicator	Messages	Cause	Action required
W-02-01-03*	Signal: yellow 	WARNING: <i>Tank cannot be filled</i>	<ul style="list-style-type: none"> – The level has dropped below NIV3a while the water inlet valve V10 is open. – Water inlet pressure or flow too low 	<ul style="list-style-type: none"> ➤ Check water supply ➤ Contact the service department
W-02-01-04*	Signal: yellow 	WARNING: <i>Inlet volume below alarm limit</i>	<ul style="list-style-type: none"> – The inflow FL-F is below the specified alarm limit. – Water inlet pressure or flow too low 	<ul style="list-style-type: none"> ➤ Check water supply ➤ Contact the service department
W-02-01-05	Signal: yellow 	WARNING: <i>Tank overflow</i>	<ul style="list-style-type: none"> – The level has risen above NIV4. – Water inlet pressure too high 	<ul style="list-style-type: none"> ➤ Check water supply ➤ Check the water inlet valve V10 (LED) ➤ Contact the service department
W-02-01-06	Signal: yellow 	WARNING: <i>Circulation flow too low</i>	<ul style="list-style-type: none"> – The circulation pump P3 fails to deliver. 	<ul style="list-style-type: none"> ➤ Contact the service department
W-02-01-07	Signal: yellow 	WARNING: <i>Alarm limit for daily consumption exceeded</i>	<ul style="list-style-type: none"> – The daily water consumption has exceeded the specified alarm limit. 	<ul style="list-style-type: none"> ➤ Check the water consumption ➤ Contact the service department
W-02-01-08*	Signal: yellow 	WARNING: <i>Failure to reach rinse volume</i>	<ul style="list-style-type: none"> – Failure to reach the specified rinse volume. – Ring main drain valve V46 defective 	<ul style="list-style-type: none"> ➤ Contact the service department
W-02-01-09*	Signal: yellow 	WARNING: <i>Fill level cannot be lowered</i>	<ul style="list-style-type: none"> – Failure to lower the break tank level to NIV2 during the storage of dialysis water. 	<ul style="list-style-type: none"> ➤ Contact the service department
W-02-01-10	Signal: yellow 	WARNING: <i>Supply, volume not reached</i>	<ul style="list-style-type: none"> – Failure to draw in the disinfection fill volume. – Insufficient disinfectant in the canister – Inadvertent consumption – Leak in the system – Contaminated filter in the disinfection suction pump PhaD 	<ul style="list-style-type: none"> ➤ Check the canister volume. ➤ Check the (disinfection) suction pump for correct function. ➤ Contact the service department



Error code	Visual indicator	Messages	Cause	Action required
W-02-01-11	Signal: yellow 	WARNING: <i>Supply not started</i>	– The disinfectant has not been connected within 15 minutes.	<ul style="list-style-type: none"> ➤ Check the disinfection suction pump for correct function. ➤ Check the disinfection connector. ➤ Contact the service department
W-02-01-12	Signal: yellow 	WARNING: <i>Fill level cannot be lowered</i>	– Failure to lower the level to NIV3a	<ul style="list-style-type: none"> ➤ Contact the service department
W-02-01-13	Signal: yellow 	WARNING: <i>Check leakage detector!</i>	– Incorrect position of the leakage detector.	<ul style="list-style-type: none"> ➤ Check, and if necessary, correct the position of the leakage sensor ➤ Contact the service department
W-02-01-14*	Signal: yellow 	WARNING: <i>Alarm limit for feed conductivity exceeded</i>	<ul style="list-style-type: none"> – The feed conductivity has exceeded the specified alarm limit. – Conductivity sensor CD-F defective – Measuring transducer B4 defective 	<ul style="list-style-type: none"> ➤ Contact the service department
W-02-01-15*	Signal: yellow 	WARNING: <i>Conductivity cell feed defective</i>	<ul style="list-style-type: none"> – The line connection to the Feed conductivity sensor is defective or interrupted. – Conductivity sensor CD-F defective – Measuring transducer B4 defective 	<ul style="list-style-type: none"> ➤ Contact the service department
W-02-01-16*	Signal: yellow 	WARNING: <i>permeate pressure below alarm limit</i>	<ul style="list-style-type: none"> – The dialysis water pressure is below the specified alarm limit. – Pressure sensor P-P defective – Booster pumps do not deliver or do not build up any pressure. – Membranes defective – Measuring transducer B4 defective 	<ul style="list-style-type: none"> ➤ Contact the service department

Error code	Visual indicator	Messages	Cause	Action required
W-02-01-17*	Signal: yellow 	WARNING: <i>concentrate pressure below alarm limit</i>	<ul style="list-style-type: none"> – The concentrate pressure is below the specified alarm limit. – Pressure sensor P-C defective – Booster pumps do not deliver or do not build up any pressure. – Measuring transducer B4 defective 	➤ Contact the service department
W-02-01-18*	Signal: yellow 	WARNING <i>Permeate temp. alarm limit exceeded</i>	<ul style="list-style-type: none"> – The dialysis water temperature T-P has exceeded the specified alarm limit during AquaA2 operation. – Temperature sensor T-P defective – Measuring transducer B4 defective 	➤ Contact the service department

5.6 Error category 03–start condition not fulfilled





An error code marked with „*“ denotes a self-confirming message.



Error code	Visual indicator	Messages	Cause	Action required
W-03-01-01*	Signal: yellow 	WARNING: <i>Rinse start, tank cannot be filled</i>	<ul style="list-style-type: none"> – Failure to reach NIV3. – Water inlet pressure too low 	<ul style="list-style-type: none"> ➤ Check water supply ➤ Contact the service department
W-03-01-02*	Signal: yellow 	WARNING: <i>Rinse start, pressure cannot be built up</i>	<ul style="list-style-type: none"> – The concentrate pressure failed to rise above the specified limit. – Pressure sensor P-C defective – Measuring transducer B4 defective 	<ul style="list-style-type: none"> ➤ Check the pumps ➤ Contact the service department
W-03-01-03*	Signal: yellow 	WARNING: <i>Rinse start, Operating point (pressure) not reached</i>	<ul style="list-style-type: none"> – Booster pump P1 defective – The motor protection switch F1 has tripped. – The concentrate pressure failed to rise above the specified limit. – Pressure sensor P-C defective – Measuring transducer B4 defective 	<ul style="list-style-type: none"> ➤ Check the pumps ➤ Contact the service department
W-03-01-04*	Signal: yellow 	WARNING: <i>Rinse start, no circulation flow</i>	<ul style="list-style-type: none"> – Flow control switch of pump P3 defective – Circulation pump P3 defective – The motor protection switch F3 has tripped. 	<p>The circulation pump P3 fails to deliver</p> <ul style="list-style-type: none"> ➤ Check the pumps ➤ Contact the service department
W-03-01-05*	Signal: yellow 	WARNING: <i>Rinse start, permeate cond. too high</i>	<ul style="list-style-type: none"> – The dialysis water conductivity CD-P failed to drop below the specified alarm limit. – Conductivity sensor CDT-P defective – Measuring transducer B4 defective 	<ul style="list-style-type: none"> ➤ Contact the service department
W-03-01-06*	Signal: yellow 	WARNING: <i>Start, tank cannot be filled</i>	<ul style="list-style-type: none"> – Failure to reach NIV3. – Water inlet pressure too low 	<ul style="list-style-type: none"> ➤ Check water supply ➤ Contact the service department

Error code	Visual indicator	Messages	Cause	Action required
W-03-01-08*	Signal: yellow 	WARNING: <i>Start, Operating point (pressure) not reached</i>	<ul style="list-style-type: none"> – The concentrate pressure failed to rise above the specified alarm limit. – Pressure sensor P-C defective – Measuring transducer B4 defective 	<ul style="list-style-type: none"> ➤ Check the pumps ➤ Contact the service department
W-03-01-09*	Signal: yellow 	WARNING: <i>Start, permeate cond. too high</i>	<ul style="list-style-type: none"> – The dialysis water conductivity CD-P has exceeded the specified alarm limit. – Conductivity sensor CDT-P defective – Measuring transducer B4 defective 	<ul style="list-style-type: none"> ➤ Contact the service department

5.7 Error category 04–Start test and test routines





An error code marked with „*“ denotes a self-confirming message.







Error code	Visual indicator	Messages	Cause	Action required
F-04-01-01	Signal: red 	FAILURE: T1 Test <i>Measuring transducer function not ensured</i>	<ul style="list-style-type: none"> – Reference measurement of test voltage (8.0 V_{DC}) failed – Measuring transducer B4 defective – Serial connection line COM1 defective – Digital output terminal A13 defective – Line connection between measuring transducer B4 and analog output terminal A13 defective 	➤ Contact the service department
F-04-01-02	Signal: red 	FAILURE: T1 Test <i>Temperature measurement, function not ensured</i>	<ul style="list-style-type: none"> – Deviation between T-F and T-P more than 5 °C – Temperature sensor T-F and T-P defective – Deviation between T-P and T-Ps more than 5 °C (for AquaA2 only) – Temperature sensor T-Ps defective (for AquaA2 only) 	➤ Contact the service department
F-04-01-04	Signal: red 	FAILURE: T1 Test <i>Booster pump 1; Function not ensured</i>	<ul style="list-style-type: none"> – The booster pump 1 fails to build up concentrate pressure. – P-C sensor defective – The motor protection switch F2 has tripped. – Measuring transducer B4 defective 	<ul style="list-style-type: none"> ➤ Check the pump ➤ Contact the service department
F-04-01-06	Signal: red 	FAILURE: <i>Permeate conductivity cell defective</i>	<ul style="list-style-type: none"> – The line connection to the dialysis water conductivity sensor is defective or interrupted. – Conductivity sensor CD-P defective – Measuring transducer B4 defective 	➤ Contact the service department







Error code	Visual indicator	Messages	Cause	Action required
W-04-01-01	Signal: yellow 	WARNING: <i>Start test: flow sensors exceeded admissible deviation</i>	<ul style="list-style-type: none"> – Deviation between FL-F and FL-C more than 20% – Flow sensor FL-F or FL-C defective 	<ul style="list-style-type: none"> ➤ Contact the service department
W-04-01-02*	Signal: yellow 	WARNING: <i>Start test, no circulation flow</i>	<ul style="list-style-type: none"> – Circulation flow delivered by circulation pump P3 too low. – Flow control switch P3ctrl defective – Circulation pump P3 defective – The motor protection switch F3 has tripped. 	<ul style="list-style-type: none"> ➤ Check the pump ➤ Contact the service department



5.8 Alarms and information messages–AquaHT (option)

An error code marked with „*“ denotes a self-confirming message.

Error code	Visual indicator	Messages	Cause	Action required
F-01-04-01	Signal: red 	FAILURE: <i>HTU BK I/O bus</i>	<ul style="list-style-type: none"> – Connection problem between the AquaA reverse osmosis system and the AquaHT system component. – The AquaHT system component is turned off. – The network connection is defective or disconnected. 	➤ Contact the service department
F-02-04-01	Signal: red 	FAILURE: <i>Fill level dropped–leakage</i>	<ul style="list-style-type: none"> – Excessive water consumption during the ring main heat disinfection heating phase. – Water consumption exceeds 50 liters during heat disinfection–heating ring main. 	➤ Contact the service department
F-02-04-02	Signal: red 	FAILURE: <i>Permeate temperature T-5P exceeded</i>	<ul style="list-style-type: none"> – The dialysis water temperature T-5P has exceeded the specified alarm limit T-P or T-Ps (AquaA2). – Temperature sensor T-5P defective – Line defective or interrupted 	➤ Contact the service department
W-01-04-01	Signal: yellow 	WARNING: <i>Temperature measurement impossible</i>	<ul style="list-style-type: none"> – Temperature sensor T-H1 defective – Temperature sensor T-H2 defective – Temperature sensor T-P /CDT-P defective – Temperature sensor T-F /CDT-F defective – Temperature sensor T-Ps /CDT-Ps defective – Temperature sensor T-5B defective – Temperature sensor T-5P defective – Lines to temperature sensors defective 	➤ Contact the service department





Error code	Visual indicator	Messages	Cause	Action required
W-02-04-01*	Signal: yellow 	WARNING: <i>run-dry protection, pump stop</i>	<ul style="list-style-type: none"> – The AquaHT break tank volume has dropped below the minimum volume. – Pressure sensor P-T5 defective – Line defective or interrupted 	➤ Contact the service department
W-02-04-02	Signal: yellow 	WARNING: <i>Fill level cannot be lowered</i>	<ul style="list-style-type: none"> – The fill level in the break tank of the AquaA has not dropped to the desired level during the heat disinfection program. – Valve V36 defective 	➤ Contact the service department
W-02-04-03	Signal: yellow 	WARNING: <i>Tank cannot be filled</i>	<ul style="list-style-type: none"> – The level in the break tank of the AquaA could not be raised to the desired level. – Valve V36 defective – Valve V10/V11 defective 	➤ Contact the service department
W-02-04-04*	Signal: yellow 	WARNING: <i>Membrane temperature not reached</i>	<ul style="list-style-type: none"> – The "Heating modules" phase lasted longer than 2 hours. – Flow heater H1 defective – Flow heater H2 defective – Temperature sensor T-F and T-H1 defective – Not possible to reach an A0 value greater than 600. 	➤ Contact the service department
W-02-04-05	Signal: yellow 	WARNING: <i>Membrane temperature exceeded</i>	<ul style="list-style-type: none"> – The dialysis water temperature has exceeded the limit of 85 °C. – Temperature sensor T-P and T-F defective – Heater relay defective 	➤ Contact the service department
W-02-04-06	Signal: yellow 	WARNING: <i>Flow FL-H1 too low</i>	<ul style="list-style-type: none"> – Pump P5 failed to generate a flow above 5 L/min. – Pump P5 defective – Flow sensor FL-H1 defective – The motor protection switch has tripped. 	➤ Contact the service department







Error code	Visual indicator	Messages	Cause	Action required
W-02-04-07*	Signal: yellow 	WARNING: <i>Ring main temperature exceeded</i>	<ul style="list-style-type: none"> – The feed temperature for the ring main heat disinfection has exceeded the target value by 10 %. – Temperature sensor T-H1 defective – Temperature sensor T-H2 defective – Flow heater H1 defective 	➤ Contact the service department
W-02-04-08	Signal: yellow 	WARNING: <i>Tank cannot be filled</i>	<ul style="list-style-type: none"> – The AquaHT tank could not be refilled within 3 hours. – Pressure sensor P-T5 defective – AquaA in FAILURE – Valve V55 defective 	➤ Contact the service department
W-02-04-09	Signal: yellow 	WARNING: <i>Tank cannot be heated</i>	<ul style="list-style-type: none"> – It took more than 4 hours to heat the AquaHT tank to the desired temperature. – Flow heater H1 defective – Temperature sensor T-H1 defective – Pump P5 defective – The motor protection switch has tripped. – Valve V55 defective – Flow sensor FL-H1 defective 	➤ Contact the service department
W-02-04-10*	Signal: yellow 	WARNING: <i>Tank temperature exceeded</i>	<ul style="list-style-type: none"> – The AquaHT tank temperature has exceeded the target value by 10 %. – Flow heater H1 relay defective – Temperature sensor T-H1 defective 	➤ Contact the service department
W-02-04-11	Signal: yellow 	WARNING: <i>Ring main temperature not reached</i>	<ul style="list-style-type: none"> – Flow heater H1 defective – Flow heater H2 defective – Pump P5 defective – The motor protection switch has tripped. – Flow sensor FL-B defective – Flow sensor FL-H1 defective – Not possible to reach an A0 value greater than 600. 	➤ Contact the service department
W-03-04-01	Signal: yellow 	WARNING: <i>Start, tank cannot be filled</i>	<ul style="list-style-type: none"> – Failure to reach NIV3. – Water inlet pressure too low 	➤ Contact the service department







Error code	Visual indicator	Messages	Cause	Action required
W-03-04-02	Signal: yellow 	WARNING: <i>Start, pressure cannot be built up</i>	<ul style="list-style-type: none"> – The concentrate pressure failed to rise above the specified alarm limit. – Pressure sensor P-C defective – Booster pump P1 defective – The motor protection switch has tripped. 	➤ Contact the service department
W-03-04-03	Signal: yellow 	WARNING: <i>Start, no circulation flow</i>	<ul style="list-style-type: none"> – The circulation pump P3 failed to generate a flow. – Flow control switch P3ctrl defective 	➤ Contact the service department
W-03-04-04	Signal: yellow 	WARNING: <i>Start, permeate cond. too high</i>	<ul style="list-style-type: none"> – The dialysis water conductivity CD-P failed to drop below the specified alarm limit. – Conductivity sensor CD-P defective – Measuring transducer B4 defective 	➤ Contact the service department





5.9 Alarms and information messages–AquaA2 (option)

An error code marked with „*“ denotes a self-confirming message.

Error code	Visual indicator	Messages	Cause	Action required
F-01-02-01	Signal: red 	FAILURE Stage 2, <i>BK I/O bus</i>	<ul style="list-style-type: none"> – BUS system connection interrupted – BUS component defective 	➤ Contact the service department
F-01-02-07	Signal: red 	FAILURE Stage 2, <i>Communication (measuring transducer)</i>	<ul style="list-style-type: none"> – Communication problem from/to measuring transducer B4 – Measuring transducer B4 defective – Serial RS232 connection line to the KL6031 measuring transducer defective 	➤ Contact the service department
F-01-02-08	Signal: red 	FAILURE Stage 2, <i>measuring transducer (ADC)</i>	<ul style="list-style-type: none"> – Reference measurement of test voltage (1.0 V_{DC}) failed – Measuring transducer B4 defective – Serial RS232 connection line to the KL6032 measuring transducer defective – Digital output terminal A8 defective – Line connection between measuring transducer B4 and analog output terminal A8 defective 	➤ Contact the service department
F-02-02-01	Signal: red 	FAILURE Stage 2, <i>Permeate cond. alarm limit exceeded</i>	<ul style="list-style-type: none"> – The dialysis water conductivity has exceeded the specified alarm limit. – Conductivity sensor CDT-Ps defective – Measuring transducer B4 defective 	<ul style="list-style-type: none"> ➤ Contact the service department ➤ This failure is confirmed automatically when the value drops below the alarm limit. The message will continue to be shown on the display, however.

Error code	Visual indicator	Messages	Cause	Action required
F-02-02-02	Signal: red 	FAILURE Stage 2, <i>permeate temp. alarm limit exceeded</i>	<ul style="list-style-type: none"> – The dialysis water temperature has exceeded the specified alarm limit. – Conductivity sensor CDT-Ps defective – Measuring transducer B4 defective 	<ul style="list-style-type: none"> ➤ Contact the service department ➤ This failure is confirmed automatically when the value drops below the alarm limit. The message will continue to be shown on the display, however.
F-02-02-03	Signal: red 	FAILURE Stage 2, <i>permeate pressure alarm limit exceeded</i>	<ul style="list-style-type: none"> – The dialysis water pressure has exceeded the specified alarm limit. – Pressure sensor P-Ps defective – Measuring transducer B4 defective 	<ul style="list-style-type: none"> ➤ Contact the service department
F-02-02-04	Signal: red 	FAILURE Stage 2, <i>conc. pressure alarm limit exceeded</i>	<ul style="list-style-type: none"> – The concentrate pressure has exceeded the specified alarm limit. – Pressure sensor P-Cs defective – Measuring transducer B4 defective 	<ul style="list-style-type: none"> ➤ Contact the service department
F-02-02-05	Signal: red 	FAILURE Stage 2, <i>run-dry protection, pump stop</i>	<ul style="list-style-type: none"> – The AquaA2 pre-pressure P-Fs is below the specified alarm limit. – AquaA not producing enough dialysis water – AquaA membranes defective 	<ul style="list-style-type: none"> ➤ Contact the service department
F-02-02-08	Signal: red 	FAILURE Stage 2, <i>leakage detector signals leakage</i>	<ul style="list-style-type: none"> – Indication of water leakage from the connected leakage sensor 	<ul style="list-style-type: none"> ➤ Check all water-carrying lines and connections. ➤ Contact the service department
W-02-02-01	Signal: yellow 	WARNING Stage 2, <i>Permeate cond. alarm limit exceeded</i>	<ul style="list-style-type: none"> – The dialysis water conductivity CD-Ps has exceeded the specified alarm limit. – Conductivity sensor CD-Ps defective – Measuring transducer B4 defective 	<ul style="list-style-type: none"> ➤ This failure is confirmed automatically when the value drops below the alarm limit. ➤ Contact the service department

Error code	Visual indicator	Messages	Cause	Action required
W-02-02-06*	Signal: yellow 	WARNING Stage 2, <i>circulation flow too low</i>	– The circulation pump P3s fails to deliver.	➤ Contact the service department
W-02-02-13	Signal: yellow 	WARNING Stage 2, <i>check leakage detector!</i>	– Incorrect position of the leakage detector.	➤ Check, and if necessary, correct the position of the leakage sensor ➤ Contact the service department
W-02-02-16*	Signal: yellow 	WARNING Stage 2, <i>permeate pressure below alarm limit</i>	– The dialysis water pressure is below the specified alarm limit. – Pressure sensor P-Ps defective – Booster pumps do not deliver or do not build up any pressure. – Membranes defective – Measuring transducer B4 defective	➤ Contact the service department
W-02-02-17*	Signal: yellow 	WARNING Stage 2, <i>conc. pressure below alarm limit</i>	– The concentrate pressure is below the specified alarm limit. – Pressure sensor P-Cs defective – Booster pumps do not deliver or do not build up any pressure. – Measuring transducer B4 defective	➤ Contact the service department
W-03-02-02*	Signal: yellow 	WARNING Stage 2, <i>rinse start, pressure cannot be built up</i>	– Booster pump P1s defective – Pressure sensor P-Cs defective – Measuring transducer B4 defective	➤ Check the pumps ➤ Contact the service department
W-03-02-04*	Signal: yellow 	WARNING Stage 2, <i>rinse start, no circulation flow</i>	– The flow control switch P3sctrl is defective. – Circulation pump P3s defective. – The motor protection switch F3 has tripped.	➤ Check the pump ➤ Contact the service department

Error code	Visual indicator	Messages	Cause	Action required
F-04-02-04	Signal: red 	FAILURE Stage 2, <i>T1 test: booster pump function not ensured</i>	<ul style="list-style-type: none"> - The booster pump P1s fails to build up concentrate pressure. - P-Cs sensor defective - The motor protection switch F1 has tripped. - Measuring transducer B4 defective 	<ul style="list-style-type: none"> ➤ Check the pump ➤ Contact the service department
F-04-02-06	Signal: red 	FAILURE Stage 2, <i>permeate conductivity cell defective</i>	<ul style="list-style-type: none"> - The line connection to the dialysis water conductivity sensor CD-Ps is defective or interrupted. - Conductivity sensor CD-Ps defective - Measuring transducer B4 defective 	<ul style="list-style-type: none"> ➤ Contact the service department
F-04-02-07	Signal: red 	FAILURE stage 2T1-Test: <i>V27 function not ensured</i>	<ul style="list-style-type: none"> - Valve V27 has failed the specified test routine. - Flow meter FL-F or FL-Fs defective 	<ul style="list-style-type: none"> ➤ Contact the service department
W-04-02-01	Signal: yellow 	WARNING Stage 2, Start test <i>flow sensors exceeded admissible deviation</i>	<ul style="list-style-type: none"> - Deviation between FL-Fs and FL-Cs more than 10% - Flow sensor FL-Fs or FL-Cs defective 	<ul style="list-style-type: none"> ➤ Contact the service department
W-04-02-02*	Signal: yellow 	WARNING Stage 2, <i>start test, no circulation flow</i>	<ul style="list-style-type: none"> - Circulation flow delivered by circulation pump P3s too low. - The circulation pump monitor P3sctrl failed to detect a flow. - The motor protection switch F3 has tripped. 	<ul style="list-style-type: none"> ➤ Check the pump ➤ Contact the service department

6 Cleaning, disinfection, preservation

6.1 Generally applicable regulations for cleaning, disinfection and preservation



Warning

Operator instructions

The device may only be cleaned, disinfected, and preserved by persons who have been instructed on the proper handling of the device during such procedures.

- The operator must observe and follow the general safety precautions.
- The system may only be disinfected after consultation with the manufacturer of the system or by persons authorized by the manufacturer.



Warning

Risk of contamination

After servicing the dialysis water circuit, the device must be disinfected.

6.1.1 General information

The disinfection procedure is program-controlled.

A preventive disinfection **once a month** is recommended. This can either be a chemical disinfection or a heat disinfection including membrane+ring main.

This interval can be adjusted depending on the results of the microbiological analysis.

6.1.2 Reasons for disinfecting the device

If a water supply as specified by the applicable regulations can no longer be ensured:

- After repairs to the dialysis water circuit.
- If the system has been idle for more than 72 consecutive hours. In the event of longer periods without use, preservation of the device is recommended.
- ISO 23500-1 (or ISO 23500 respectively) "Guidance for the preparation and quality management of fluids for haemodialysis and related therapies" recommends a regular (e.g., monthly) preventive disinfection to avoid significant biofilm formation (biofouling).

**Recommended
disinfectant**

Minnicare®

6.1.3 Requirements for the clinic technician (Clinic Technician training)

The clinic technician (**Clinic Technician** training) performing the disinfection must be familiar with the following information before starting the disinfection:

- **Complete system installation/installation layout**

- Number of user points (e.g., dialysis machines, media supplies, concentrate preparation devices, tank filling, etc.)
- Position of the user points
- Number of building levels affected

- **Time schedule/dialysis-free time of the station**

Disinfection must be performed only during dialysis-free time. Please refer to the last completed Disinfection Report to obtain the time required for chemical disinfection.



Note

The starting time of the subsequent dialysis must not be jeopardized.

- **Functioning and design of the equipment**

The clinic technician (**Clinic Technician** training) must be familiar with the functioning and design of the devices to perform the job properly (have Instructions for Use and the relevant chapters in the Service Manual ready).

- All operating steps are carried out on the **AquaA** and at the user points on the dialysis water ring main. There is no need to carry out any work on any optional **AquaA2**, **AquaHT** and **RingBase** equipment during the disinfection process.

6.2 Precautions

6.2.1 Patient safety



Warning**Risk for the patient from disinfectants and cleaning agents**

Ensure that no dialysis devices are connected during the entire cleaning, disinfection, and preservation procedure.

- Prior to cleaning, disinfection, and preservation, all dialysis devices connected to the ring main must be disconnected.
- All systems which cannot be disconnected (e.g., concentrate mixing system) must be rinsed separately.
- Systems which cannot be disconnected must only be released again once they have been checked for residual disinfectant.



Warning**Risk for the patient from residual disinfectants, cleaning agents, and preservation solutions**

- When using disinfectants, perform a suitable test to ensure the absence of residual disinfectant at the drain, overflow, and user points of the **AquaA** as well as at all user points on the dialysis water ring main.
 - If additional options such as **AquaHT**, **AquaUF** and **AquaA2** are connected, these must also be checked for residual disinfectant.
 - If the test shows a residual concentration of disinfectant, the rinse program must be repeated until all residual disinfectant has been completely removed.
-

6.2.2 Operator safety



Warning

Risk of caustic burning when working with acidic or alkaline substances (concentrated substance or disinfectant/cleaning agent)

- Be careful when handling acidic or alkaline fluids and do not spill any disinfectant concentrate.
- Rubber gloves (acrylonitril latex, cotton-lined) should be worn to avoid contact with the skin.
- Wear goggles!
- Observe the safety precautions for the concentrated substance/disinfectant/cleaning agent used.

In the event of contact with acid or alkaline solutions:

Eye: Immediately rinse with running water for 15 minutes.

Skin: Rinse thoroughly under running water and also use soap to neutralize.

Ingestion: Do not induce vomiting, but have the victim drink plenty of non-carbonated water. Seek medical advice.



Warning

Safe handling of chemicals

When using chemicals and concentrates (e.g., disinfectants, cleaning agents, and preservation solutions), observe the manufacturer's safety precautions and instructions for use:

- The expiration date printed on the container
- The storage conditions
- Allocation to the corresponding cleaning and disinfection program or use on the device
- Different disinfectants, cleaning agents, and preservation solutions must not be mixed.

Incorrect use of such chemicals (e.g., concentration, temperature range, contact time) may:

- damage the device
 - negatively affect the effectiveness of the disinfecting, cleaning or preserving agent.
-

6.3 Disinfection

6.3.1 General notes

Operating principle	The disinfection procedure is program-controlled.
Reason for a disinfection	<ul style="list-style-type: none"> – If a water supply as specified by the applicable regulations can no longer be ensured: – After repairs to the dialysis water circuit. – If the system has been idle for more than 72 hours. In the event of longer periods without use, preservation of the device is recommended. – ISO 23500-1 (or ISO 23500 respectively) "Guidance for the preparation and quality management of fluids for haemodialysis and related therapies" recommends a regular (e.g., monthly) preventive disinfection to avoid significant biofilm formation (biofouling).
Recommended disinfectant	Minnicare®

6.3.2 Disinfecting the system



Warning

Operator instructions

The device may only be cleaned, disinfected, and preserved by persons who have been instructed on the proper handling of the device during such procedures.

- The operator must observe and follow the general safety precautions.
 - The system may only be disinfected after consultation with the manufacturer of the system or by persons authorized by the manufacturer.
-



Note

If the microbiological tests indicate a persistent microbial count in the dialysis water, shorten the disinfection interval.

6.4 Preservation



Note

Reasons for preservation

Preservation is necessary to prevent clogging or bacterial growth in the module unit when the system is decommissioned for a prolonged period.

For preservation of the system, contact the manufacturer.



Warning

Efficacy of the preservation solution

Storage time in the preserved state: maximum **12 months**.

- To prevent bacterial growth, the **AquaA** must be subjected to another preservation procedure in case of prolonged storage times and, particularly, in case of increased storage temperatures.
-

6.5 Surface cleaning

6.5.1 General information

If the surface is contaminated by dust and dirt, clean the housing surface.



Warning

Disconnect the device from the power

Touching live parts will cause an electric shock.

- Before cleaning/disinfecting the surface, disconnect the power plug to disconnect the device from the power supply.
-



Note

Surface cleaning agents

Do not use any abrasives or aggressive cleaning agents and solvents.

- If the housing is extremely dirty, wipe the affected sections with a damp cloth.
 - Use a soft cloth or a brush to remove dust and dirt from the housing surface.
 - The interior of the **AquaA** may only be cleaned by a service technician.
-

**Note****To be observed for surface cleaning**

- Do not use any cleaning agents which contain acetone.
- Do not use solvents, diluting agents, or chemical cleaning sprays.
- Do not use any aggressive cleaning agents and solvents or abrasives.
- Do not use rough cleaning tools (e.g., scouring pad or similar) to clean the system.

6.6 Surface disinfection

6.6.1 General information

**Warning****Disconnect the device from the power**

Touching live parts will cause an electric shock.

- Before cleaning/disinfecting the surface, disconnect the power plug to disconnect the device from the power supply.

**Note**

The manufacturer recommends the surface disinfectants indicated in the chart below. When performing surface disinfecting follow the disinfectants manufactures instructions for use.

- The manufacturer does not assume any liability for potential damage to the surface if a different disinfectant than the one recommended is used.

6.6.2 Surface disinfectant

Specification	Surface disinfectant
Alcohol-based surface disinfectants	Surface disinfectants with ethanol (~ 80 % ethanol)
Chlorine-based surface disinfectants	Chlorine bleach , in solution, max. 5 % bleach
Peroxide-based surface disinfectants	Oxivir five 16 concentrate (concentrate) Oxivir Tb / Oxivir Tb Wipes (ready-to-use wipes)

7 Functional description

This chapter provides a brief functional description of the **AquaA** reverse osmosis system.

7.1 Description of the procedure

7.1.1 Functions

The **AquaA** is an industrial PC-controlled, fully automated reverse osmosis system which uses pretreated soft water for the production of highly deionized water, also called dialysis water.

The device consists of a water inlet section where the inflowing volume of water is volumetrically measured and controlled in relation to the flow (controlled shut-off).

The water is stored in a break tank and supplied to the pumps to generate high pressure. Two pumps which are connected in series, generate the high pressure and transport the water to the semi-permeable membranes.

From the membranes, the dialysis water flows upwards to the dialysis water outlet via the dialysis water collector, passing through pressure, temperature and conductivity measurement along the way.

If the conductivity values exceed the programmed required value for maximum conductivity, the dialysis water is returned to the break tank via a bypass (on the **AquaA** or **RingBase**). To maintain the programmed yield and the necessary diversion to drain, a small high-pressure pump ensures circulation of the concentrate by bypassing the membranes. This ensures silent, highly effective and economical operation.

The concentrate to be discarded flows via a motor-controlled restrictor to the drain.

7.1.2 RingBase

The dialysis water can be discarded via the **RingBase** before it enters the ring main. This is particularly important during the start phase after the system has been out of use for a longer period of time, in order to prevent dialysis water with higher conductivity from entering the ring main. The water from the ring return can also be directed directly into the drain.

7.1.3 RingUnit (option)

Depending on the size of the device or the local conditions (topography of the ring main), several ring mains may be required. A **RingUnit** is required to operate several ring mains. Using an adjustable pressure-holding valve and a direct flow indicator, it allows the flows in the different ring mains to be adjusted.

7.1.4 Flow diagrams



Note

For flow diagrams, please contact the technical service department.

8 Consumables, accessories, additional equipment



Warning

Risks affecting the proper functioning of the device

The device has been approved for use with certain consumables and accessories. Should the responsible organization wish to use other consumables and accessories than those listed in this chapter, the suitability must be checked beforehand by gathering the appropriate manufacturer information.

The applicable legal regulations must be complied with.

The manufacturer does not assume any responsibility or liability for personal injury or other damage, and the use of non-approved or unsuitable consumables or accessories resulting in damage to the device will void the warranty.

Upon request the local service will provide information about further accessories, consumables, and other additional equipment.

8.1 Consumables

	Description	Information	Part number
1	Replacement fuses	for AquaA consisting of: <ul style="list-style-type: none"> – 2 x glass-tube, fine-wire fuse 5 x 20 5 A T – 1 x fuse ATOF 1A – 4 x fuse ATOF 2A – 2 x fuse ATOF 3A – 1 x fuse ATOF 4A – 2 x fuse ATOF 7.5A 	M13000114 M13000514 M13000515 M13000518 M13000516 M13000517
2	Glass fuse	AquaA2, AquaHT <ul style="list-style-type: none"> – Glass-tube, fine-wire fuse 5 x 20 5 A T – 	M13000114
3	Bag/adapter	Sampling set for standard configuration	G03000832
4	Sampling set for the Fresenius sampling valve	Sampling set for insulated ring main	G03000836

8.2 Additional equipment/options

	Description	Information	Part number
1	AquaA–AquaA2 connection set		G04020116
2	RingUnit 1 AquaA		G03020147
3	RingUnit 2/3 AquaA		G03020148
4	Metal brace RingBase/RingUnit ; installation set on the device, complete		G03020140
5	Metal brace RingBase/RingUnit	installation set on wall, complete	G03020153
6	Connection line 1100	AquaA module placeholder	G03000822
7	Connection 1–2 m, ball valve	Emergency mode AquaA2	G04001170
8	Clamp restrictor 5	Flow reducer for short ring mains	G03020302
9	PVDF connecting tube set	Placeholder 133 mm, incl. clamp	G03020056
10	PVDF connecting tube set	Placeholder 300 mm, incl. clamp	G03020055
11	PVDF connecting line set	Placeholder 480 mm, incl. clamp and holder	G03020053
12	Installation kit or retrofit kit	Additional status relays for AquaA	G04020147
13	Additional status indicator (beacon)	Status indication	G05000500
14	Option sample port emergency operation AquaA2		G03020200
15	Software CD TSDiag+		A13000621
16	Inlet block with sample port AquaA		G03020314

8.3 Modules/Accessories

The devices listed below are modules/accessories of the **AquaA**, and can be connected to the **AquaA**.

	Description	Information	Part number
1	DataCOM Standard	incl. Wi-Fi	G05000068-US
2	AquaDETECTOR	Leakage monitoring system	G04000673-US
3	Visual LED Indicator	Remote status monitoring system	G04020127-US
4	AquaA2 1000	Second filter stage, 1000 L/h	G02020410-US
5	AquaA2 2000	Second filter stage, 2000 L/h	G02020420-US
6	AquaA2 3000	Second filter stage, 3000 L/h	G02020430-US
7	AquaA2 4000	Second filter stage, 4000 L/h	G02020440-US
8	AquaA2 900H	Second filter stage, 900 L/h; Can be heat disinfected	G02020310-US
9	AquaA2 1800H	Second filter stage, 1800 L/h; Can be heat disinfected	G02020320-US
10	AquaA2 2700H	Second filter stage, 2700 L/h; Can be heat disinfected	G02020330-US
11	AquaA2 3600H	Second filter stage, 3600 L/h; Can be heat disinfected	G02020340-US
12	AquaHT	Heat disinfection tank	G02020200-US
13	AquaUF 2250; single	Optional ultrafilter UF 2250, single filter for increased dialysis water quality; up to 2250 L/h	G04020300-US
14	AquaUF 4000; dual	Optional ultrafilter UF 4000, dual filter for increased dialysis water quality; up to 4000 L/h	G04020301-US

9 Installation

9.1 Installation requirements

9.1.1 General information

Follow the applicable installation guidelines

For new installations, the applicable installation guidelines must be followed.

To be observed before the operational qualification

- The water pretreatment system must be completed before the Operational Qualification of the reverse osmosis system.
- Fresenius Water Technology can plan and carry out the work.

Observe national and local regulations

The national or local installation, operation, use, and maintenance regulations must be complied with.

9.1.2 Environment

Observe the local conditions

- The installation site must be free from frost and dust, and must also be level. The floor load must be sufficient for the weight of the components to be installed.
- The components must not be exposed to continuous, direct sunlight.
- The control electronics for the device must be protected from moisture.

Variations in temperature

Variations in temperature during transport may cause condensation, leading to water developing on live parts. In the event of major variations in temperature, allow sufficient time for the system to adjust to the ambient temperature before the operational qualification.

9.1.3 Power supply system (electrical)



Note

The device may only be used in accordance with the accompanying documents.

Only then will the manufacturer consider himself liable for the safety, reliability and performance of the device.

- Operational Qualification must be performed by the technical service department of the manufacturer or a person authorized by the manufacturer.
 - Be sure to observe the Specifications when installing the reverse osmosis system for the first time.
 - When bringing the reverse osmosis system from a cooler to a warmer room, allow approx. 2 hours for the system to adjust to the ambient temperature before turning it on.
-

Connection to a power supply system

When connecting the device to a power supply, the relevant national standards and regulations must be observed.

Protective conductor

When using protection class I devices, the quality of the protective conductor of the installation is of particular importance. It must be taken into consideration that in many countries regulations have been enacted by the national authorities.

Basic electrical installation

Basic electrical installations must be installed correctly by an electrical contractor in accordance with ANSI/NFPA 70.

Installation of the device

- The device should not be installed directly next to other electrical devices. Stacked installation is not permitted.
- If the device must be operated close to other electrical devices, it must be checked if the performance of a device is negatively affected by inadvertent electromagnetic coupling.
- When installing the device, it must be ensured that all controls and indicators are easily accessible and that the labels on the device are legible.

9.2 Operational Qualification

9.2.1 To be observed before Operational Qualification

Tester's qualification	Operational Qualification must be performed by the technical service department of Fresenius Medical Care or a person authorized by them. The Operational Qualification may only be performed by persons qualified to properly perform the specified checks based on their educational background, training, knowledge, and experience. Furthermore, the persons performing the checks must not be bound by any directives when performing this activity.
Only for Operational Qualification	The following information is only intended for the operational qualification. It is not applicable for operational requalification of devices that have been removed from service or temporarily shut down.
Specifications	<ul style="list-style-type: none"> – Observe the information on the specifications. – Specific connection and performance data must be taken from the Specifications chapter.
Electromagnetic radiation	Do not use devices emitting electromagnetic radiation (e.g., walkie-talkies, mobile phones, radio transmitters) in the vicinity of the device in operation. This may cause a malfunction of the device.
Power plug	The power plug must be easily accessible.
Use of spare parts	Any installation, modification or repair work requiring the device to be opened may only be performed by manufacturer-authorized persons and is permitted only when using original spare parts.
Test equipment and accessories	The activities described in this document require the availability of the necessary technical test equipment and accessories.
Precautions	<p>Before turning power on, repair any visible damage.</p> <p>Prior to opening the device and when working on the open device, the following precautions must be observed:</p> <ul style="list-style-type: none"> ➤ Protect the components against ingress of fluids. ➤ Do not touch live parts. ➤ Disconnect and connect all jacks, connectors and components only when the device is turned off.
ESD precautions	When repairing the system and when replacing spare parts, observe the applicable ESD precautions.

9.3 System-specific requirements

9.3.1 General information



Note

Follow the applicable installation guidelines

- For new reverse osmosis system installations, the applicable installation guidelines must be followed.
-



Note

Condition on delivery

- The **AquaA** is delivered in a preserved state.
 - The **AquaA** is electrically and hydraulically aligned when it is delivered.
-

9.3.2 Hydraulic connection requirements



Note

If the soft water does not reach the necessary water quality values, a suitable pretreatment system must be implemented upstream.

9.3.3 Requirements for electric connections

● Connection to the power supply

- A socket complying with the specifications on the identification label must be present.
- Additional extension cables, multipoint connectors or couplings may not be used.
- When bringing the **AquaA** from a cooler to a warmer room, allow approx. 2 hours for the device to adjust to the ambient temperature before turning the device on.

● Protective conductor

When using protection class I devices, the quality of the protective conductor is of particular importance during installation. The national specifications defined by foreign authorities must be considered.

9.4 Operational Qualification procedure



Note

When performing Operational Qualification on the reverse osmosis system, the descriptions in the Service Manual must be followed.

9.4.1 After Operational Qualification



Warning**Risk of contamination**

After Operational Qualification, a chemical disinfection must be performed on the **AquaA**. The successful disinfection must be verified by means of a microbiological analysis.



Note

- The senior physician must be informed about the results of the microbiological analysis. The Technical Safety Checks must be performed and reported.
-

9.5 Decommissioning / shutdown / operational requalification



Note

Reasons for preservation

Preservation is necessary to prevent clogging or bacterial growth in the module unit when the system is decommissioned for a prolonged period.

For preservation of the system, contact the manufacturer.

9.5.1 Decommissioning



Note

- For information regarding the decommissioning or shutdown of the device, contact the local service department.
-



Note

If the reverse osmosis system is decommissioned after the operational qualification, the following has to be observed:

- On operational requalification, the water supply pressure must be checked against the prescribed minimum pressure.
-

9.5.2 Shutdown



Note

- For information regarding shutdown of the device, contact the local service department.
-

9.5.3 Operational requalification



Note

When delivered, the device has already undergone operational qualification.

Strictly speaking, when the device is installed it is an operational requalification which is performed, although this is nevertheless treated as an operational qualification.



Note

- For information regarding operational requalification of the device, contact the local service.

10 Transport/storage

10.1 Transport and storage conditions



Note

The following transport and storage conditions and further information regarding transport and storage affect the main **AquaA** device and the options **AquaA2** and **AquaHT**.



Warning

Efficacy of the preservation solution

Storage time in the preserved state: maximum **12 months**.

- To prevent bacterial growth, the **AquaA** must be subjected to another preservation procedure in case of prolonged storage times and, particularly, in case of increased storage temperatures.

- The device must be stored in a well-ventilated room with little variation in temperature.

Position



Note

Store upright!

Storage temperature range

+5 °C to +40 °C



Note

Protect the device from frost!

Relative air humidity

20 to 70 % at 20 °C, non-condensing

Atmospheric pressure

500 hPa to 1150 hPa



Note

Protection from exposure to UV light

Do not expose the device to direct sunlight (UV rays may cause faster aging of the materials).

Do not store outdoors!

10.2 Transport



Note

For further information regarding transport, please contact the manufacturer.

Only authorized persons or service technicians are permitted to transport the device.

10.3 Environmental compatibility/disposal

Within the EU member states, the device must be disposed of in accordance with the "Directive on waste electrical and electronic equipment" (WEEE directive). Please also observe the applicable local legal regulations.

Before returning or disposing of the device, the responsible organization must ensure that all of the consumables attached to the device have been removed and that the system has been disinfected in accordance with the manufacturer's specifications (see Chapter 6 on page 6-1).

The responsible organization must also inform the disposal plant responsible for dismantling and disposing of the device of the following before the start of the disposal measures:

- It is possible that the device may be contaminated when returned. Therefore, it is vital to take suitable precautions when dismantling it, such as wearing personal protective equipment.
- Batteries and rechargeable batteries must be disposed of properly in accordance with the local legal regulations.
- The manufacturer can provide further information if requested to do so by the disposal plant.

● Handling of disinfectants

It is absolutely essential to observe the manufacturer's specifications of the disinfectants used (e.g., protective clothing, storage, dosing, expiration date).

The local conditions for the disposal of waste water must have been clearly clarified prior to the use of the disinfectant and must be observed.

11 Technical Safety Checks and maintenance

11.1 Important information for the procedure

Checks	The Technical Safety Checks must be performed every 24 months.
Tester's qualification	<p>The checks must be performed by the service department of the manufacturer or a person authorized by the manufacturer.</p> <p>The checks may only be performed by persons qualified to properly perform the specified checks based on their educational background, training, knowledge and experience. Furthermore, the persons performing the checks must not be bound by any directives when performing this activity.</p>
Specifications	Observe the information on the specifications.
Documentation	<p>To perform the Technical Safety Checks and the maintenance procedures, contact the local service department.</p> <p>Reports can be provided on request.</p> <p>Performance of the Technical Safety Checks must be entered in the Medical Device Register.</p>

11.2 Maintenance procedures

Maintenance procedures are not defined for the operator.

12 Specifications

12.1 Dimensions and weight

Dimensions

Height	1840 mm
Width	610 mm
Depth	1200 mm

Weight

empty	300 kg
filled	500 kg
Break tank fill volume	75 L

12.1.1 Device data

Dialysis water capacity	<ul style="list-style-type: none"> – 1000 L/h, 2000L/h, 3000 L/h, 4000 L/h (at 15 °C and a counter-pressure of 2 bar) – 1000 L/h per pressure vessels* <p>or</p> <ul style="list-style-type: none"> – 900 L/h* in case of the heat-disinfectable membranes <p>Thus 900 L/h, 1800 L/h, 2700 L/h, 3600 L/h (at 15 °C and a counter-pressure of 2 bar)</p> <p>* The specified nominal capacity is only valid for water temperatures of 15 °C and a counter-pressure of 2 bar. At temperatures below this, a 3 % decrease in output per degree can be expected. At higher temperatures, the product water output will increase accordingly.</p>
Efficiency	<ul style="list-style-type: none"> – 70 to 85 % default – 50 to 85 % adjustable
Rejection rate	<ul style="list-style-type: none"> > 99 % for bacteria and endotoxins > 96 % for dissolved salts (average)
Concentrate pressure	Max. 19.9 bar

12.2 Identification label (device identification)

The identification label shown is only an example. The actual data is the data specified on the identification label of the device.

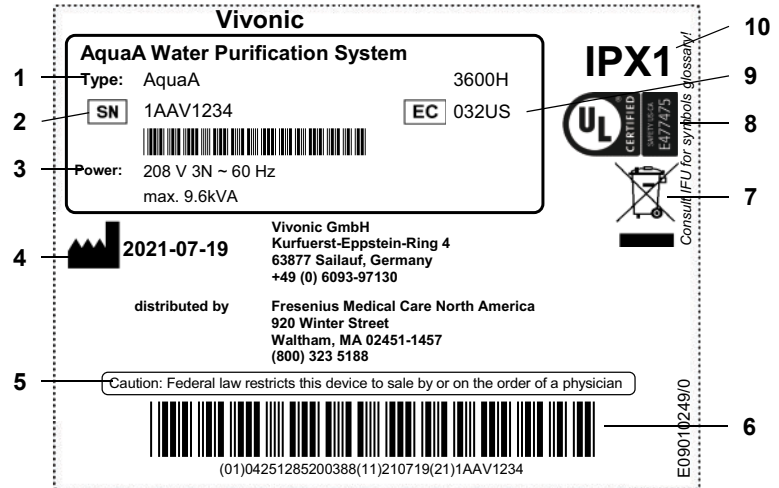

- 1 Type identification
- 2 Serial number
- 3 Power input
- 4 Manufacturer: Date of manufacture and manufacturer's address
- 5 Regulatory note in accordance with 21 CFR 801.109(b)(1)
- 6 UDI - Unique Device Identifier
- 7 Identification of electrical and electronic devices
- 8 UL Safety and Identity Mark as to electrical shock, fire and mechanical hazards only, in accordance with ANSI/AAMI ES60601- 1:2005 + C1:2009 + A2:2010 + A1:2012, IEC 60601-1-6:2010 + A1:2013, CAN/CSA-C22.2 No. 60601-1:2014, CAN/CSA-C22.2 No. 60601-1- 6:2011 + A1:2015
- 9 Equipment code (EC)
- 10 Degree of protection against ingress of fluids: Drip-proof (IPX1)

12.3 Electrical safety

	Classification according to ANSI/AAMI ES60601-1
Type of protection against electric shock	Protection class I
Type of applied part (degree of patient protection)	Type B
Degree of protection against ingress of fluids	Drip-proof (IPX1)
Leakage currents	According to ANSI/AAMI ES60601-1
Additional parameters	
Installation altitude	up to 3000 m (AquaHT up to 2000 m)
Overvoltage category	II
Pollution severity	II
Material group	III b
Operating mode	Continuous operation

12.4 Electrical supply



Warning

Risk of injury caused by electric shock

Without a protective ground connection, there is a risk of electric shock.

- Always connect the device to a power supply network with a protective earth conductor.

System type	900H/1000/1800H/2000	2700H/3000/3600H/4000
Line voltage	208 V, 60 Hz	
Power supply	hardwired	
Protection	20 A (for AquaA 900H/1000/1800H/2000) 32 A (for AquaA 2700H/3000/3600H/4000) Tripping characteristic C, D, K or comparable	
Power consumption	6.0 kVA	9.6 kVA
Power line impedance	< (0.24 + j0.15) ohm	



Note

- A residual current device (RCD) or other suitable measure must be provided so that the conditions for preventing interruptions of the neutral conductor are fulfilled.
- The manufacturer recommends using a residual current device (RCD) which operates at 30 mA.

An overvoltage protection device must be installed to prevent damage to the fuse in the power distribution box of the **AquaA** system. This can occur when a surge impulse is caused by an atmospheric source, such as a thunderstorm, or by an unstable power supply.

When using fuses, replacement is recommended every 24 months as part of the periodic maintenance (MA) procedures.

The use of 3-pole circuit breakers is recommended.

12.5 Fuses

The following is a list of the fuses installed in the **AquaA**:

Part number	Fuse
(see chapter 8.1 on page 142)	AquaA replacement fuses set consisting of: <ul style="list-style-type: none">– 2 x glass-tube, fine-wire fuse 5 x 20 5 A T– 1 x fuse ATOF 1 A– 4 x fuse ATOF 2 A– 2 x fuse ATOF 3 A– 1 x fuse ATOF 4 A– 2 x fuse ATOF 7.5 A

12.6 Information on electromagnetic compatibility (IEC 60601-1-2)

Specifications refer to the requirements of IEC 60601-1-2.



Note

In the event of a possible loss of essential performance affecting the **AquaA**, **AquaA2** and **AquaHT**, the system can generate alarms which are described in Chapter 5.

12.6.1 Essential performance

The essential performance of the **AquaA** is to provide water for dialysis according to ISO 13959 "Water for haemodialysis and related therapies". The conductivity of the incoming water and of the produced permeate are measured to assure the quality of the permeate and indicate the rejection rate of **AquaA**.

12.6.2 Minimum distances between radiation source and medical electrical equipment

Medical electrical devices are subject to special protective measures with regard to electromagnetic compatibility (EMC).



Warning

Risk for the patient as a result of a device malfunction

Portable and mobile radio-frequency telecommunication devices (radio devices including their accessories, such as antenna cables and external antennas) should not be used at a distance of less than 30 cm (12 inches) to the parts and cables of the device designated by the manufacturer. Non-compliance may result in impairment in the performance of the device.

- Always maintain a distance of at least 30 cm between portable and mobile radio-frequency telecommunication devices and the device.
-

Portable and mobile radio-frequency telecommunication devices can include the following sources of radiation (example devices): mobile phone, smartphone, tablet PC, cordless phone, notebook/laptop, wireless keyboard, wireless mouse, wireless speaker, wireless remote control (The device-specific wireless remote control provided by the manufacturer is not affected.)



Warning**Risk for the patient as a result of a device malfunction**

The use of electrical accessories and cables other than those specified in the Instructions for Use can lead to an increase in electromagnetic emissions or a reduction in electromagnetic immunity of the device.

- Only use the accessories and cables approved by the manufacturer.
-



Warning**Risk for the patient as a result of electromagnetic incompatibility between devices**

Electromagnetic interference from other devices can cause device malfunctions.

- Do not operate the device in the immediate vicinity of other devices.

If operation in the immediate vicinity of other devices cannot be avoided:

- Monitor the device to verify that it is working properly.
-

12.6.3 Guidance and manufacturer's declaration on EMC



Warning

Risk for the patient as a result of a device malfunction

The **AquaA**, **AquaA2**, **AquaUF** and **AquaHT** are not suitable for use in the following environments:

- Use in a home care setting
- Use in the vicinity of radio-frequency equipment
- Use in the vicinity of CT or X-ray equipment
- Use in emergency medical services
- Use as a portable system
- Use in the vicinity of transmitting facilities

● **Electromagnetic emissions**

Guidance and manufacturer's declaration – electromagnetic emissions		
The AquaA device is intended for use in the electromagnetic environment specified below. The customer or the user of the AquaA device should assure that it is used in such an environment.		
Emissions test	Compliance	Electromagnetic environment – guidance
RF emissions CISPR 11	Group 1, Class A	The AquaA device uses RF energy only for its internal function. Therefore, its RF emissions are very low and are not likely to cause any interference in nearby electronic equipment.
Harmonic emissions IEC 61000-3-2	not applicable (for 208 V; 60 Hz)	The AquaA device is suitable for use in all establishments other than domestic and those directly connected to the public low-voltage power supply network that supplies buildings used for domestic purposes. The emissions characteristics of the AquaA make it suitable for use in industrial areas and hospitals (CISPR 11, Class A). If it is used in a residential environment (for which CISPR 11 class B is normally required) this equipment might not offer adequate protection to radio-frequency communication services. The user may need to take mitigating measures, such as relocating or re-orienting the equipment.
Voltage fluctuations/flicker emissions IEC 61000-3-3	not applicable (for 208 V; 60 Hz)	

● **Electromagnetic immunity**

Guidance and manufacturer's declaration – electromagnetic immunity			
The AquaA device is intended for use in the electromagnetic environment specified below. The customer or the user of the AquaA device should assure that it is used in such an environment.			
Immunity test	IEC 60601-1-2 test level	Compliance level	Electromagnetic environment – guidance
Electrostatic discharge (ESD) IEC 61000-4-2	±8 kV contact ±2 kV, ±4 kV, ±8 kV, and ±15 kV air	±8 kV contact ±2 kV, ±4 kV, ±8 kV, and ±15 kV air	Floors should be wood, concrete or ceramic tile. If floors are covered with synthetic material, the relative humidity should be at least 30%.
Electrical fast transient/burst IEC 61000-4-4	±2 kV for power supply lines	±2 kV for power supply lines	Mains power quality should be that of a typical commercial or hospital environment.
Surge IEC 61000-4-5	±0.5 kV and ±1 kV normal mode voltage ±0.5 kV, ±1 kV and ±2 kV common mode voltage, line(s) to earth	±0.5 kV and ±1 kV normal mode voltage ±0.5 kV, ±1 kV and ±2 kV common mode voltage, line(s) to earth	Mains power quality should be that of a typical commercial or hospital environment.
Voltage dips, short interruptions and voltage variations on power supply input lines IEC 61000-4-11	0 % U_T for 0.5 cycle (at 0, 45, 90, 135, 180, 225, 270 and 315 degrees) 0 % U_T for 1 cycle 70 % U_T for 25 cycles at 50 Hz or 30 cycles at 60 Hz 0 % U_T for 250 cycles at 50 Hz or 300 cycles at 60 Hz	0 % U_T for 0.5 cycle (at 0, 45, 90, 135, 180, 225, 270 and 315 degrees) 0 % U_T for 1 cycle 70 % U_T for 25 cycles at 50 Hz or 30 cycles at 60 Hz 0 % U_T for 250 cycles at 50 Hz or 300 cycles at 60 Hz	In the event of a short power supply interruption, the AquaA device will turn off. Mains power quality should be that of a typical commercial or hospital environment.
Power frequency (50/60 Hz) magnetic field IEC 61000-4-8	30 A/m	30 A/m	Power frequency magnetic fields should be at levels characteristic of a typical location in a typical commercial or hospital environment.
Note: U_T is the a.c. mains voltage prior to application of the test level.			

Guidance and manufacturer's declaration – electromagnetic immunity			
The AquaA device is intended for use in the electromagnetic environment specified below. The customer or the user of the AquaA device should assure that it is used in such an environment.			
Immunity test	IEC 60601-1-2 test level	Compliance level	Electromagnetic environment – guidance
Conducted RF IEC 61000-4-6	3 V _{rms} 150 kHz to 80 MHz 6 V _{rms} in ISM bands between 150 kHz and 80 MHz	3 V _{rms} 150 kHz to 80 MHz 6 V _{rms} in ISM bands between 150 kHz and 80 MHz	Portable and mobile radio-frequency telecommunication devices (radio devices including their accessories, such as antenna cables and external antennas) should not be used at a distance of less than 30 cm (12 inches) to the AquaA . Non-compliance may result in impairment in the performance of the device.
Radiated RF IEC 61000-4-3	3 V/m 80 MHz to 2.7 GHz 9 V/m 704 to 787 MHz 5100 to 5800 MHz 27 V/m 380 to 390 MHz 28 V/m 430 to 470 MHz 800 to 960 MHz 1700 to 1990 MHz 2400 to 2570 MHz	3 V/m 80 MHz to 2.7 GHz 9 V/m 704 to 787 MHz 5100 to 5800 MHz 27 V/m 380 to 390 MHz 28 V/m 430 to 470 MHz 800 to 960 MHz 1700 to 1990 MHz 2400 to 2570 MHz	
<p>Note: These guidelines may not apply in all situations. Electromagnetic propagation is affected by absorption and reflection from structures, objects and people.</p> <p>Field strengths from fixed transmitters, such as base stations for radio (cellular/cordless) telephones and land mobile radios, amateur radio, AM and FM radio broadcast and TV broadcast cannot be predicted theoretically with accuracy. To assess the electromagnetic environment due to fixed RF transmitters, an electromagnetic site survey should be considered. If the measured field strength in the location in which the AquaA device is used exceeds the applicable RF compliance level above, the AquaA device should be observed to verify normal operation. If abnormal performance is observed, additional measures may be necessary, such as re-orienting or relocating the AquaA device.</p>			

12.7 Operating conditions

Operating temperature range +5 to 35 °C

Radiated heat/losses

Rated output* in L	900 L to 1000 L	1800 L to 2000 L	2700 L to 3000 L	3600 L to 4000 L
Radiated heat**	960 W	1160 W	1200 W	1260 W

* The specified nominal capacity is only valid for water temperatures of 15 °C and a counter-pressure of 2 bar. At temperatures below this, a 3 % decrease in output per degree can be expected. At higher temperatures, the product water output will increase accordingly.

Noise level Noise level in **SUPPLY** mode; max. 68 to 72 dB(A) at a distance of 1 m

Atmospheric pressure 700 to 1150 hPa

Relative air humidity 20 to 80 % at 20 °C, non-condensing

Water inlet temperature 5 °C to 35 °C

Feed pressure dynamic 1.5 to 5 bar

Inlet volume

Capacity*	Efficiency				
	50 %	60 %	70 %	80 %	85 %
900 to 1000 L/h	2000 L/h	1670 L/h	1430 L/h	1250 L/h	1180 L/h
1800 to 2000 L/h	4000 L/h	3340 L/h	2860 L/h	2500 L/h	2360 L/h
2700 to 3000 L/h	6000 L/h	5000 L/h	4290 L/h	3750 L/h	3530 L/h
3600 to 4000 L/h	8000 L/h	6670 L/h	5720 L/h	5000 L/h	4710 L/h

*The actual water volume required depends on the effective yield. The water required for water pretreatment must also be considered.

The specified nominal capacity is only valid for water temperatures of 15 °C and a counter-pressure of 2 bar. At temperatures below this, a 3 % decrease in output per degree can be expected. At higher temperatures, the product water output will increase accordingly.

Feed water quality



Warning

Risk for the patient from deviating water inlet quality

The design of the water treatment system must ensure that the necessary parameters are fulfilled.

Parameter	Values	Unit
Water hardness	< 1	°dH
Total chlorine	< 0.1	mg/L
Iron*	< 0.1	mg/L
Manganese*	< 0.05	mg/L
Silicate*	< 25	mg/L
Max. conductivity	2500	µS/cm
SDI* (Silt-Density Index or colloid index)	< 3	---
pH	6 to 8	---
* The parameters for iron, manganese, silicate, and SDI in the inlet water should be checked before the water pretreatment components are dimensioned.		



Warning

Risk for the patient due to damage to the membrane

Deviating water quality can reduce the service life of the membrane. This may require the membrane to be replaced prematurely.

➤ Ensure compliance with the necessary parameters.

Water pretreatment

Pretreatment of the water is determined after previous water analysis.

Sensors

Measured value	Sensor	Measuring range	Unit	Accuracy
Dialysis water conductivity	CD-P	0.0 to 100.0	µS/cm	±5 % of the MV*; ±0.1 µS/cm
		100 to 2500		±10 % of the MV*; ±0.1 µS/cm
Inlet conductivity	CD-F	0.0 to 100.0	µS/cm	±5 % of the MV*; ±0.1 µS/cm
		100 to 2500		±10 % of the MV*; ±0.1 µS/cm
Dialysis water temperature	T-P	0.0 to 115.0	°C	±2 °C
Inlet temperature	T-F	0.0 to 115.0	°C	±2 °C
Dialysis water pressure	P-P	0.0 to 10.0	bar	±1%
Concentrate pressure	P-C	0.0 to 20.0	bar	±1%

Measured value	Sensor	Measuring range	Unit	Accuracy
Feed flow	FL-F	4.0 to 160.0	L/min	±10 %
Diversion	FL-C	4.0 to 160.0	L/min	±10 %
*MV = measured value, actual value				

12.8 Transport/storage

For further information (see chapter 10 on page 153)

12.9 External connection options

Other, additional equipment connected to this device must comply with the applicable IEC or ISO standards (e.g., IEC 60950-1 for information technology equipment).

Furthermore, all system configurations shall comply with the requirements for medical systems (see Annex I to ANSI/AAMI ES60601-1).

Connecting the device to an IT network that contains components not installed and validated by the manufacturer can introduce unknown risks for patients, operators or third parties. These risks must be identified, analyzed, evaluated and monitored by the responsible organization. For assistance, consult IEC 80001-1 and Annexes H5 and H6 to ANSI/AAMI ES60601-1.

Any modification to an IT network that has been installed and validated by the device manufacturer can introduce new risks and therefore require a repeat analysis. Especially problematic activities include:

- Modifications to the IT network configuration
- Connection of additional components and devices to the IT network
- Removal of components and devices from the IT network
- Updates or upgrades of components and devices in the IT network

Note that local laws take priority over the above-mentioned requirements. If in doubt, contact the local service department.

● Device connections

Ethernet (TCP/IP)

Interface for the exchange of data. Electrically isolated by transformer. Port: **RJ45**

Only systems complying with the regulations or IEC 60950-1 may be connected to the LAN ports.

Service/diagnostics

For inhouse computer diagnosis.
Port: **RJ45**



Warning

Risk for the patient as a result of corrupted data

Data corruption or data loss caused by the network and the server software cannot be detected by the device. This can lead to malfunctions.

- The system installer must ensure that device data is processed securely, e.g., in PC software applications.
 - The network operator must ensure that any data transferred without encryption is protected.
-

Alarm output

For the connection of an external indicator (staff call or remote control). (potential-free alarm output, alternating contact maximum 24 V/24 W).

Warning output

For the connection of an external indicator (staff call or remote control). (potential-free alternating contact maximum 24 V/24 W).

Emergency operation output

For the connection of an external indicator (staff call). (potential-free alternating contact maximum 24 V/24 W).

Standby output

For the connection of an external indicator (staff call or remote control). (potential-free alternating contact maximum 24 V/24 W).

Supply output

For the connection of an external indicator (staff call or remote control). (potential-free alternating contact maximum 24 V/24 W).

Rinse output

For the connection of an external indicator (staff call). (potential-free alternating contact maximum 24 V/24 W).

Disinfection output

For the connection of an external indicator (staff call). (potential-free alternating contact maximum 24 V/24 W).

Heat disinfection output

For the connection of an external indicator (staff call). (potential-free alternating contact maximum 24 V/24 W).

● **System inputs**



Tip

The system inputs are to be used for the remote control function.

Standby input

Control input: external switchgear must have an electric strength of at least 4 kV.

Supply input

Control input: external switchgear must have an electric strength of at least 4 kV.

External failure input	Signal input: external switchgear must have an electric strength of at least 4 kV.
External leakage input	(e.g. AquaDETECTOR): Signal input: external switchgear must have an electric strength of at least 4 kV.
Tank control input	Signal input: external switchgear must have an electric strength of at least 4 kV.
External locking input	Control input: external switchgear must have an electric strength of at least 4 kV.

12.10 Materials used

12.10.1 Device materials

Component	Material
Piping	Stainless steel V4A, PVDF
Housing	Metal, powder-coated
Temperature sensor	Stainless steel V4A
Pressure sensor (membrane)	Ceramics/stainless steel
Flow switch	Stainless steel V4A
Valves / ball valves	Stainless steel V4A
Seals	EPDM, VITON, silicone seals

According to ISO 10993-1, components coming into contact with dialysis water must be biocompatible.

12.11 Specifications–AquaA2

- **Dimensions and weight**

Dimensions

Height	1840 mm
Width	610 mm
Depth	1200 mm (incl. piping 1410)

Weight

empty	280 kg
filled	410 kg

- **Device data**

Dialysis water capacity	1000 L/h, 2000L/h, 3000 L/h, 4000 L/h (at 15 °C and a counter-pressure of 2 bar) 1000 L/h* per pressure vessels or 900 L/h* for heat-disinfectable membranes. Thus 900 L/h, 1800 L/h, 2700 L/h, 3600 L/h (at 15 °C and a counter-pressure of 2 bar) * The indicated rated output applies for water temperatures of 15 °C. With lower temperatures, an output of 3% less per degree must be expected. At higher temperatures, the product water output will increase accordingly.
Efficiency	85 to 95 %
Rejection rate	> 99 % for bacteria and endotoxins > 96 % for dissolved salts (average)
Concentrate pressure	Max. 19.9 bar
Maximum operating pressure of dialysis water	max. 6 bar

● **Electrical connection**

AquaA2 system capacity	900H/1000/1800H/2000	2700H/3000/3600H/4000
Line voltage	208 V, 60 Hz	
Power supply	hardwired	
Protection	20 A (for AquaA2 900H/1000/1800H/2000) 25 A (for AquaA2 2700H/3000/3600H/4000) Tripping characteristic C, D, K or comparable	
Power consumption	5.2 kVA	7.2 kVA
Power line impedance	< (0.24 + j0.15) ohm	



Warning

Risk of injury caused by electric shock

Without a protective ground connection, there is a risk of electric shock.

- Always connect the device to a power supply network with a protective earth conductor.



Note

- A residual current device (RCD) or other suitable measure must be provided so that the conditions for preventing interruptions of the neutral conductor are fulfilled.
- The manufacturer recommends using a residual current device (RCD) which operates at 30 mA.

An overvoltage protection device must be installed to prevent damage to the fuse in the power distribution box of the **AquaA** system. This can occur when a surge impulse is caused by an atmospheric source, such as a thunderstorm, or by an unstable power supply.

When using fuses, replacement is recommended every 24 months as part of the periodic maintenance (MA) procedures.

The use of 3-pole circuit breakers is recommended.

- **Fuses**

Part number	Fuse
(see chapter 8.1 on page 142)	Glass fuse 5 x 20, 5 A T
(see chapter 8.1 on page 142)	ATOF fuse DIN 72581-3C 2A

- **Materials used for the device**

The materials used for the **AquaA2** device are identical to those specified for the **AquaA** device.

- **Identification label (device identification)**

For information on the identification label (see chapter 12.2 on page 158).

- **Electrical safety**

Classification according to ANSI/AAMI ES60601-1.



Tip

The technical specifications are identical with the specifications for the **AquaA**.

- **Operating conditions**

The operating conditions are identical to the **AquaA**.

- **Information on electromagnetic compatibility (IEC 60601–1–2)**



Tip

The technical specifications are identical with the specifications for the **AquaA**.

- **Transport/storage**

For further information (see chapter 10 on page 153)

- **External connection options**



Tip

The technical specifications are identical with the specifications for the **AquaA**.

12.12 Specifications–AquaHT

- **Dimensions and weight**

Dimensions

Height	1840 mm
Width	610 mm (at the tank 800 mm)
Depth	1200 mm (incl. piping 1410)

Weight

empty	200 kg
filled	620 kg

- **Device data**

Heater output	Max. 19.5 kW
Tank volume	adjustable between 100 and 380 liters
Tank temperature	adjustable from 65 to 85 °C
Ring main temperature (heat disinfection)	adjustable from 60 to 87 °C
Membrane temperature (heat disinfection)	adjustable from 60 to 82 °C
Maximum pressure	max. 6 bar
Maximum length of ring main	



Note

The length of the ring mains is restricted as follows:

- Ring length per ring main **max. 250 m**
- With three ring mains **max. 600 m** in total
- The ring mains must have thermal insulation.

Heat disinfection cycles

for ring main heat disinfection:

- Unlimited

for module heat disinfection:

- 160 cycles



Note

If the maximum number of module heat disinfection cycles is exceeded, a reduction of the dialysis water output must be expected.

Heat disinfection-type membranes are produced with a service life of 160 heat disinfection cycles.

If the membranes are heat disinfected on a weekly basis, a service life of 3 years is to be expected for the membranes.

● **Identification label (device identification)**

For information on the identification label (see chapter 12.2 on page 158).

● **Electrical safety**

Classification according to ANSI/AAMI ES60601-1.



Tip

The technical specifications are identical with the specifications for the AquaA.

Differing parameters

Parameter	Values
Installation altitude	Up to 2000 m
Overvoltage category	II
Pollution severity	II
Material group	III b
Operating mode	Continuous operation

● **Electrical supply**

Electrical connection



Note

A residual current device (RCD) or other suitable measure must be provided so that the conditions for preventing interruptions of the neutral conductor are fulfilled.

System type	900 to 3600
Line voltage	208 V, 60 Hz
Power supply	80 A Tripping characteristic C, D, K or comparable
Power consumption	22 kVA
Power line impedance	< (0.15 + j0.15) ohm

An overvoltage protection device must be installed to prevent damage to the fuse in the power distribution box of the **AquaA** system. This can occur when a surge impulse is caused by an atmospheric source, such as a thunderstorm, or by an unstable power supply.

When using fuses, replacement is recommended every 24 months as part of the periodic maintenance (MA) procedures.

The use of 3-pole circuit breakers is recommended.



Warning

Risk of injury caused by electric shock

Without a protective ground connection, there is a risk of electric shock.

- Always connect the device to a power supply network with a protective earth conductor.

● Fuses

Part number	Fuse
(see chapter 8.1 on page 142)	Glass fuse 5 x 20, 5 A T
(see chapter 8.1 on page 142)	ATOF fuse DIN 72581-3C 2A

● Information on electromagnetic compatibility (IEC 60601–1–2)



Tip

The technical specifications are identical with the specifications for the **AquaA**.

● **Operating conditions**

Only the conditions which deviate from the specifications for the **AquaA** are listed.

Development of heat

Approximately equal to the electrical energy

Maximum temperature



Note

As the atmospheric pressure decreases with increasing altitude of the place of installation and the boiling temperature increases accordingly, the maximum temperatures must be reduced accordingly:

- < 800 m: **85 °C**
 - 800 to 1400 m: **82 °C**
 - 1400 to 2000 m: **79 °C**
-

Feed water

Dialysis water

● **Transport/storage**



Note

The technical specifications are identical with the specifications for the **AquaA**. For further information (see chapter 10 on page 153).

Only differing or supplemental information will be provided here.

-
- To prevent bacterial growth, the **AquaHT** must be completely drained (including the tank) in case of prolonged storage times and particularly in case of increased storage temperatures.

● **External connection options**



Tip

The technical specifications for external connection options are identical to the specifications in Chapter 12 (see chapter 12.9 on page 169).

● **Materials used for the device**

The materials used for the **AquaHT** device are identical to those specified for the **AquaA** device.

12.13 Specifications–AquaUF

Only the conditions which deviate from the specifications for the **AquaA** are listed.

	Single ultrafilter	Dual ultrafilter	Environmental conditions
Flow	2500 L/h	4000 L/h	(at 15 °C and Δp 1 bar)
Pressure drop	0.7 bar	1.2 bar at 4000 L/h	at 15 °C
Max. inlet pressure	6 bar	6 bar	at 50 °C
Max. inlet pressure	4 bar	4 bar	at 80 °C
Dimensions W/H/D	1600/400/400	1600/400/400	
Weight empty/filled	28/35 kg	32/45 kg	

- **Operating conditions**

Development of heat	None
Feed water	Dialysis water of the AquaA
Water inlet temperature	+5 °C to 35 °C (for heat disinfection, the values for the AquaHT apply)
Inlet volume AquaA	Rated output

- **Storage conditions**



Note

The **AquaUF** must be stored in a well-ventilated room with little variation in temperature.

To prevent bacterial growth, the **AquaUF** must be completely drained in case of prolonged storage times and particularly in case of increased storage temperatures.

Storage temperature range	+5°C to +40°C
----------------------------------	---------------

Note

Protect the device from frost!

Relative air humidity	Max. 70 % at 20 °C; non-condensing
------------------------------	------------------------------------



Note

Protection from exposure to UV light

Do not expose the device to direct sunlight (UV rays may cause faster aging of the materials).

Do not store outdoors!

● **External connection options**

None

● **Materials used**

No other material than the material listed for the **AquaA** has been used.

13 Definitions













13.1 Definitions and terms

Dialysate	The exchange fluid used in dialysis.
Dialysis water	A high-pressure pump, membrane module, and appropriate monitoring equipment are used to produce dialysis water from drinking water.
Initial operational qualification	Initial start-up
Operational qualification	previously start-up
Operational requalification	previously recommissioning
Permeate	This term is used as a synonym for dialysis water. This term must only be used in a technical context and on the user interface.

13.2 Abbreviations

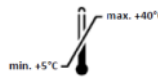
AC	Alternating current
CD	Conductivity
DC	Direct current
Fig.	Figure (diagram)
LED	Light-emitting diode
MA	Maintenance
REACH	Registration, Evaluation, Authorisation and Restriction of Chemicals
RO	Reverse osmosis system
TSC	Technical Safety Checks

13.3 Symbols

	Dialysis water feed
	Dialysis water return
IN	Soft water inlet
	Drain
IPX1	Degree of protection against ingress of fluids: Drip-proof (IPX1)
	Type of applied part (degree of patient protection): Type B
	Alternating current
	Protective earth; type of protection against electric shock: Protection class I
	Dangerous voltage
ON/I OFF/O	ON/OFF
1.5-5 bar	Permissible feed pressure
	Store upright!
	Permissible storage temperature range
	Protect against sunlight (UV light)!
Max. storage time	4 weeks when not preserved 12 months when preserved
	UL Safety and Identity Mark as to electrical shock, fire and mechanical hazards only, in accordance with ANSI/AAMI ES60601- 1:2005 + C1:2009 + A2:2010 + A1:2012, IEC 60601-1-6:2010 + A1:2013, CAN/CSA-C22.2 No. 60601-1:2014, CAN/CSA-C22.2 No. 60601-1-6:2011 + A1:2015
	Identification of electrical and electronic devices (Device may not be disposed of with household waste.)
	Caution: dangerous electrical voltage



Caution



Hot surface



Manufacturer with year indicating manufacturing date



Serial number



Equipment code



Follow the Instructions for Use!



Disconnect the power plug before opening!

13.4 Certificates

Upon request the local service will provide the currently valid versions of the certificates.

14 Options

14.1 AquaA2

14.1.1 Preface

As the **AquaA2** is an extension of the **AquaA** reverse osmosis system, the following chapters will only appear once as part of the documentation for the **AquaA**.

For better reference the affected chapters will only be listed here:

in chapter 1 of the AquaA

– Index–**AquaA2**

in chapter 2 of the AquaA

– Important information–**AquaA2**

– Target group–**AquaA2**

– Duties of the responsible organization–**AquaA2**

– Operator responsibility–**AquaA2**

– Disclaimer of liability–**AquaA2**

– Technical documentation–**AquaA2**

– Warnings–**AquaA2**

– Residual risks–**AquaA2**

– Addresses–**AquaA2**

in chapter 5 of the AquaA

– Alarms–**AquaA2**

in chapter 9 of the AquaA

– Installation–**AquaA2**

in chapter 10 of the AquaA

– Transport/storage–**AquaA2**

in chapter 11 of the AquaA

– Technical Safety Checks/maintenance–**AquaA2**

14.1.2 Functional description–AquaA2

- **Brief description–AquaA2**



The **AquaA2** option is an extension for the **AquaA** and is used to obtain a two-stage dialysis water production and distribution system. This option does not affect the operating phases, but works synchronous to the **AquaA**.

ECO operation is supported by a reduction of the output. This contributes to an energy-efficient two-stage reverse osmosis operation.

The **AquaA2** is thus fully integrated into the **AquaA** system as a module and represents the expansion of the **AquaA** product line by an additional efficient member for the production of high-purity dialysis water.

The use of an **AquaHT** module ensures automatic and stable sanitization.

- **Intended use–AquaA2**

Field of application

The **AquaA2** option is an extension to the **AquaA** to obtain a two-stage reverse osmosis system. The field of application of the **AquaA** remains the same. The extension improves the quality of the product water.

- **Side effects–AquaA2**

The improvement of quality involves a slightly reduced output compared to that of a single-stage device. This does however not lead to a higher water consumption as the concentrate of the second stage is returned to the first stage.

- **Contraindications–AquaA2**

– none

- **Restrictions–AquaA2**

– none

14.1.3 Design–AquaA2

- Front view/connection unit of AquaA and AquaA2



Legend:

- 1 **E-box 2** - control electronics
- 2 **E-box 1** - power electronics
- 3 Main power switch
- 4 Emergency operation switch (optional)
- 5 Circulation pump
- 6 Booster pump
- 7 Membrane pressure vessels
- 8 Hydraulic unit
- 9 Concentrate return to the **AquaA**
- 10 Dialysis water outlet
- 11 Dialysis water inlet

14.1.4 Operating modes–AquaA2



Tip

The **AquaA2** is completely integrated into the operating modes of the **AquaA** and has therefore no individual operating modes.

Any deviations during the start phases are described in the respective chapters.

14.1.5 STANDBY device status–AquaA2

Turning STANDBY on

- Before turning the **AquaA2** on, it must be connected to the **AquaA** via an Ethernet cable and must be activated on in the Configuration menu.
- The **AquaA2** can then be turned on with the main power switch on the **E-box 1** of the **AquaA2**.

14.1.6 SUPPLY mode–AquaA2

The **AquaA** produces dialysis water, which is monitored and delivered to the dialysis water distribution system by the **AquaA2**. The programmed yield is adjusted by the **AquaA**.

14.1.7 RINSE mode–AquaA2

The device cleans itself with water by rinsing all line branches and by exchanging the ring main and device volume.

14.1.8 DISINFECTION mode–AquaA2

During the entire disinfection program, the **AquaA2** is active. The **AquaA** disinfectant is also used to clean the **AquaA2**.

14.1.9 EMERGENCY MODE mode–AquaA2

For a detailed description of the emergency mode of the **AquaA2** (see chapter 4.8.4 on page 64).

14.1.10 STATUS Start/Stop–AquaA2

The **AquaA2** is controlled by the start/stop switching program of the **AquaA** and therefore does not have its own switching program.

14.1.11 Cleaning, disinfection, preservation–AquaA2



Tip

For information on cleaning, disinfection, and preservation of the **AquaA2**, refer to the main chapters of the **AquaA**.

14.1.12 Consumables, accessories, additional accessories–AquaA2

For further information (see chapter 8.1 on page 142).

14.2 AquaHT

14.2.1 Preface

Since the **AquaHT** is an option for extending the **AquaA** reverse osmosis system, the chapters listed below only appear once as part of the documentation for the **AquaA**.

For better reference and to save space, the affected chapters will only be listed here:

(see contents in chapter 1 of the AquaA)

– Index–**AquaHT**

(see contents in chapter 2 of the AquaA)

– Important information–**AquaHT**

– Target group–**AquaHT**

– Duties of the responsible organization–**AquaHT**

– Operator responsibility–**AquaHT**

– Disclaimer of liability–**AquaHT**

– Technical documentation–**AquaHT**

– Warnings–**AquaHT**

– Residual risks–**AquaHT**

– Addresses–**AquaHT**

(see contents in chapter 5 of the AquaA)

– Alarms–**AquaHT**

(see contents in chapter 9 of the AquaA)

– Installation–**AquaHT**

(see contents in chapter 10 of the AquaA)

– Transport/storage–**AquaHT**

(see contents in chapter 11 of the AquaA)

– Technical Safety Checks/maintenance–**AquaHT**

14.2.2 Functional description–AquaHT



The **AquaHT** is an extension module for the **AquaA** reverse osmosis system and has been selected by the responsible organization as a supplemental component in order to obtain a dialysis water production and supply unit that can be disinfected using heat.

The module does not change the existing functions or operating phases of the **AquaA**, it simply complements them. Additional functions and operating phases are as follows:

- Heat disinfection of the reverse osmosis system with membranes
- Heat disinfection of the dialysis water ring main
- Interface heat disinfection
Supply of hot dialysis water to the dialysis devices and their connecting lines while heat disinfection of the dialysis water ring main is in progress.
- Rinsing of the ring main without a **AquaA** start (with the tank option)

● Intended use–AquaHT

Fields of application

The **AquaHT** is intended to be used as a supplemental module to a **AquaA**. It performs a heat disinfection of the **AquaA** as well as the dialysis water distribution system.

Membrane life



Note

The membrane life is primarily determined by the number of heat disinfection cycles. A potential reduction of the membrane performance generally occurs after 160 heat disinfection cycles.

Restrictions

- Ring main heat disinfection is restricted to ring mains with a maximum length of 3 x 250 m (600 m in total).
- For interface heat disinfection, the volume of hot dialysis water supplied to the dialysis devices is restricted and the temperature which can be reached is influenced by the tank temperature, the heater output, and heat loss.

14.2.3 Design–AquaHT

● Front view/rear view–AquaHT

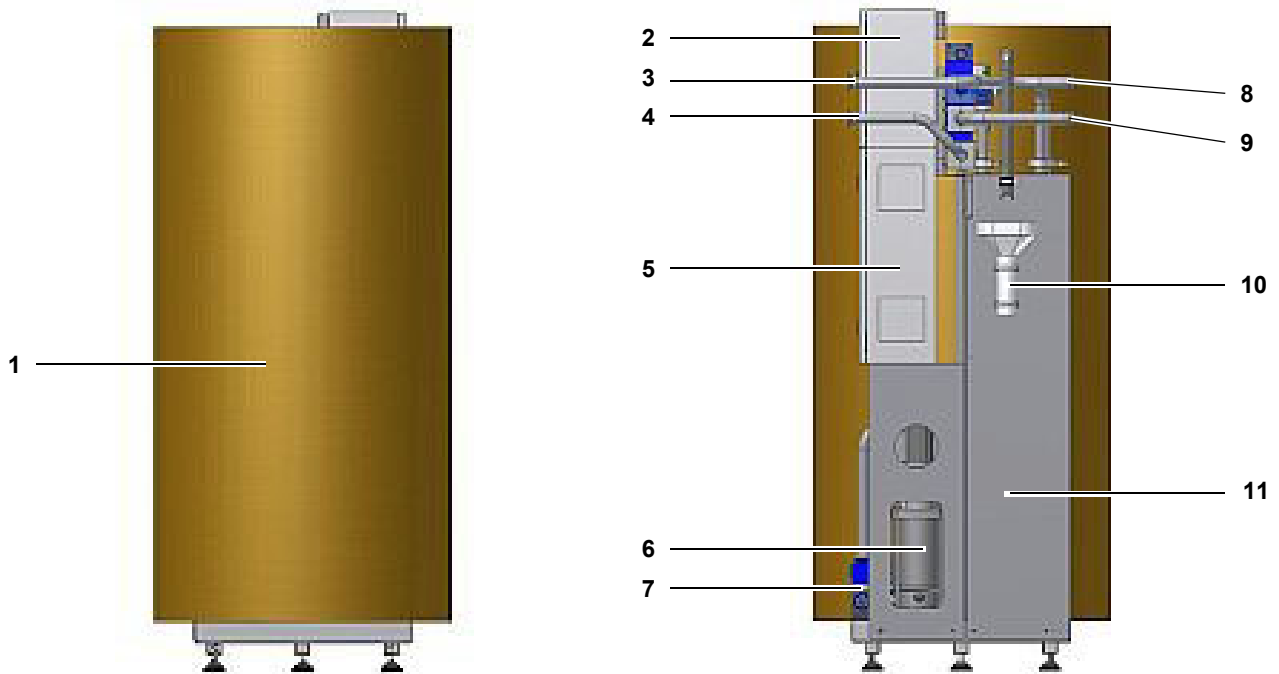

Legend:

- 1 Tank
- 2 **E-box 2**–control electronics
- 3 Dialysis water feed to ring main
- 4 Dialysis water return from ring main
- 5 **E-box 1**–power electronics
- 6 Circulation pump
- 7 Pump inlet group
- 8 Feed from **AquaA**
- 9 Return to **AquaA**
- 10 Drain (tank overflow)
- 11 Flow heater cabinet

● Side view—from left/from right—AquaHT



Legend:

- 1 Dialysis water feed from **AquaA**
- 2 Dialysis water return to **AquaA**
- 3 Hydraulic unit
- 4 Flow heater cabinet
- 5 Tank T5
- 6 Tank drain
- 7 Circulation pump
- 8 **E-box 1**—power electronics
- 9 Main power switch
- 10 **E-box 2**—control electronics
- 11 Dialysis water return from ring main (bottom rear connection, concealed)
- 12 Dialysis water feed to ring main (top rear connection, concealed)

14.2.4 HEAT DISINFECTION mode–AquaHT

- Operating modes and display messages/overview

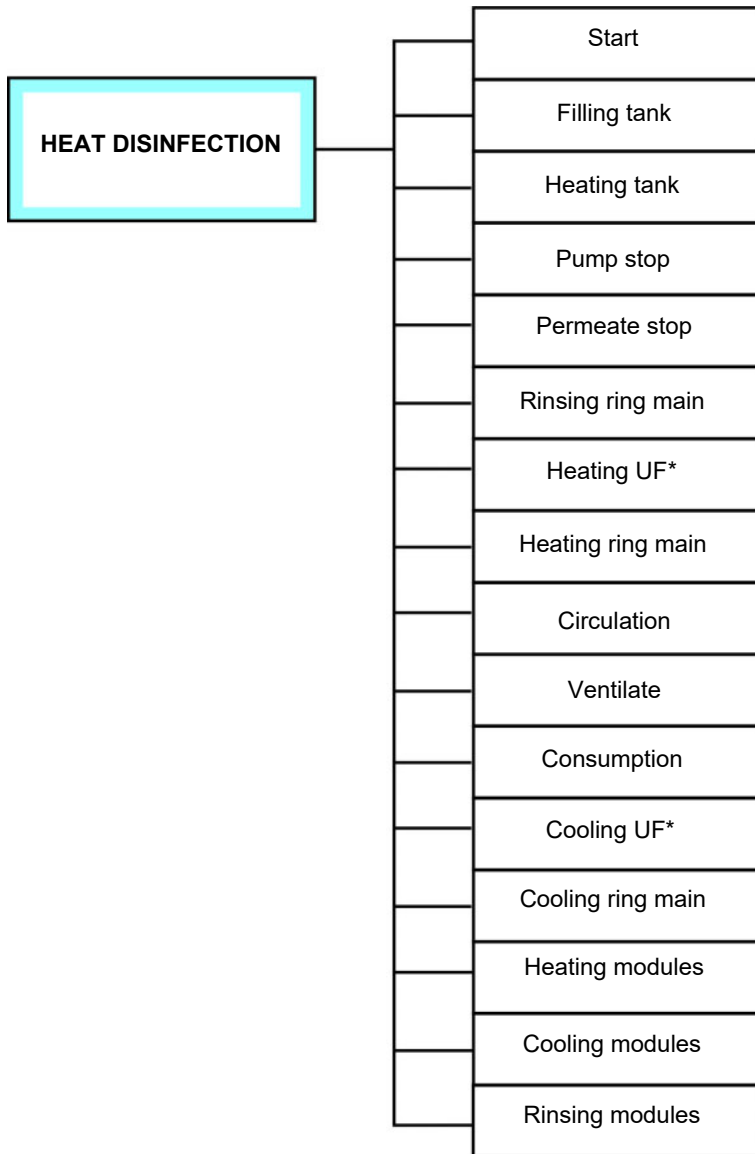

In this operating mode, all components of the **AquaHT** are used for heat disinfection of the **AquaA** or the ring main.

This operating mode can only be carried out if the **AquaHT** is connected and activated.

The **HEAT DISINFECTION** mode can only be started if there are no current alarm messages.

* = **AquaUF** option present

- **Device status STANDBY**

Turning the device On

Before turning the **AquaHT** on, it must be connected to the **AquaA** via an Ethernet cable and must be activated in the Configuration menu.

The **AquaHT** can then be turned on with the main power switch on the **E-box 1** of the **AquaHT**.

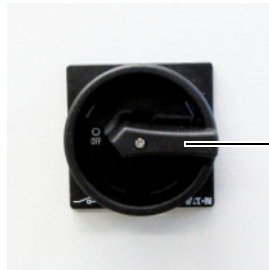
Main power switch

Main power switch
in OFF position

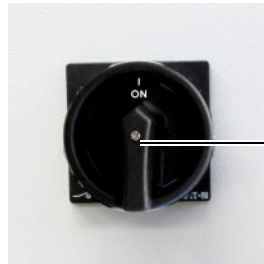

Main power switch
in ON position

● **Starting the HEAT DISINFECTION mode**

Before starting a heat disinfection for the first time, the **HEAT DISINFECTION** mode must be configured by the service technician.



Warning

Operator instructions

The device may only be cleaned, disinfected, and preserved by persons who have been instructed on the proper handling of the device during such procedures.

- The operator must observe and follow the general safety precautions.
- The system may only be disinfected after consultation with the manufacturer of the system or by persons authorized by the manufacturer.

4 steps to perform a heat disinfection of the AquaA

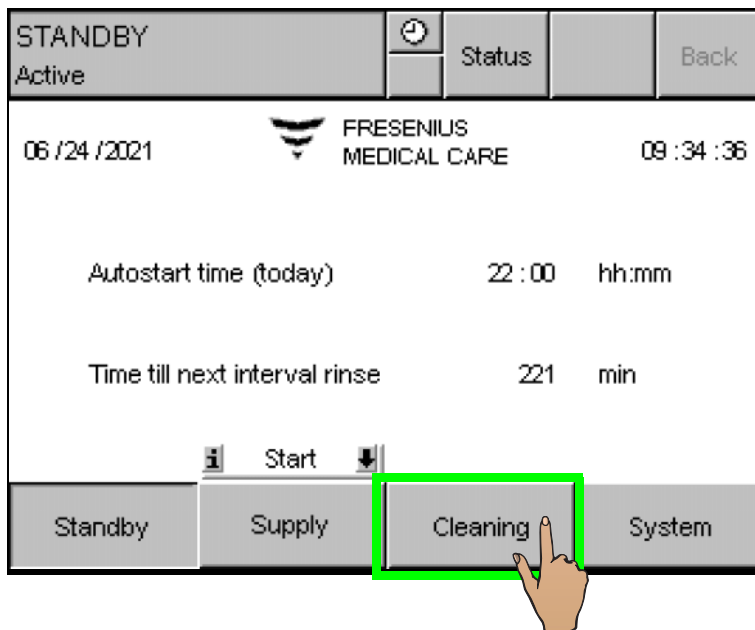

Step 1:

Open the Cleaning menu

To switch to the **Cleaning** menu, select the **Cleaning** button on the display.

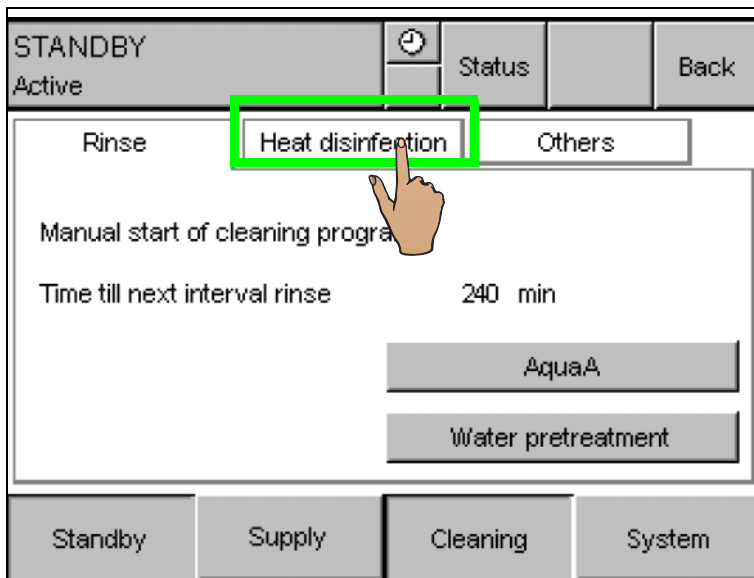

Step 2:

Switch to the **HEAT DISINFECTION** menu

- To switch to the **HEAT DISINFECTION** menu, press the **Heat disinfection** tab.

Step 3

Entering the password

A heat disinfection can only be started after entering a password.



Tip

For further information on the password, please contact the authorized technician.

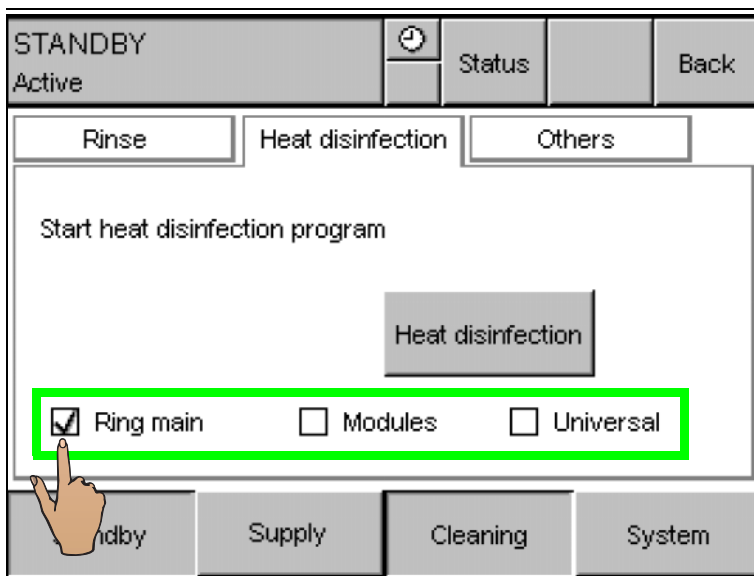

Step 4:

Selecting heat disinfection

- The type of heat disinfection must be selected before starting the heat disinfection program.

The following heat disinfection programs are available:

Ring main:

Disinfection of the ring main with the option of an interface heat disinfection of the dialysis devices.

Modules:

- Disinfection of the modules with hot dialysis water.

Universal:

- Sequential run of the Ring main and Modules program.

● **General heat disinfection phases**

Filling tank

The filling and reheating of the **AquaHT** tank is independent of the selected type of heat disinfection.

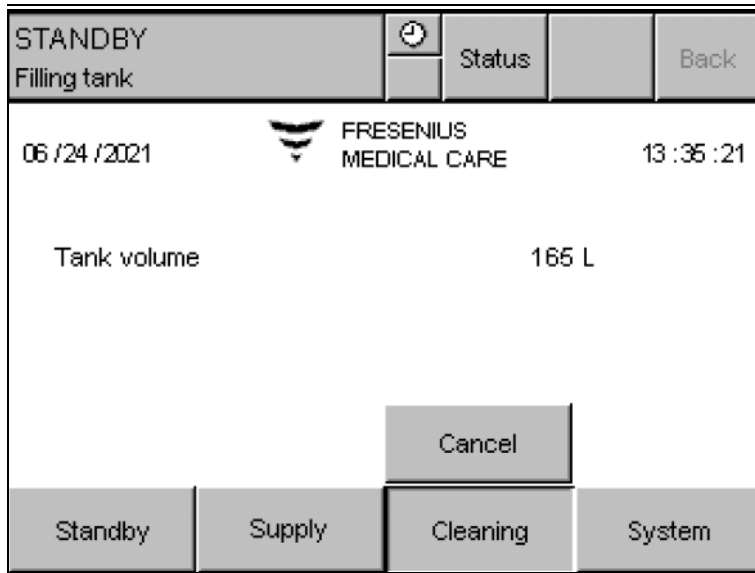

If the tank level is below the required fill volume, the tank is replenished using dialysis water from the **AquaA**. In this step, the **AquaA** is switched to a fill mode and supplies only the **AquaHT** with dialysis water.

Heating tank

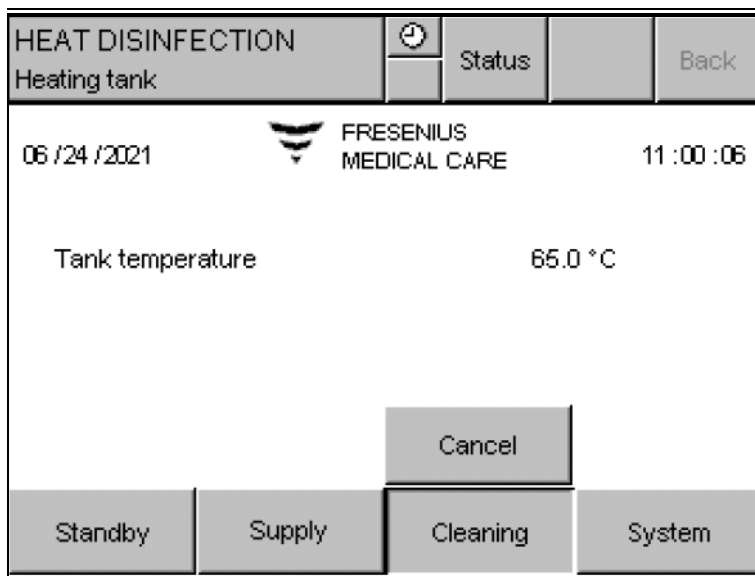

Before each heat disinfection program, the contents of the **AquaHT** tank are reheated, if required. When the programmed tank temperature has been achieved, the actual heat disinfection program will be started.

● **Ring main heat disinfection**

Example temperature graph during ring main heat disinfection:

The temperature graph shows the temperature over time during ring main heat disinfection:

Diagram of a ring main heat disinfection over time

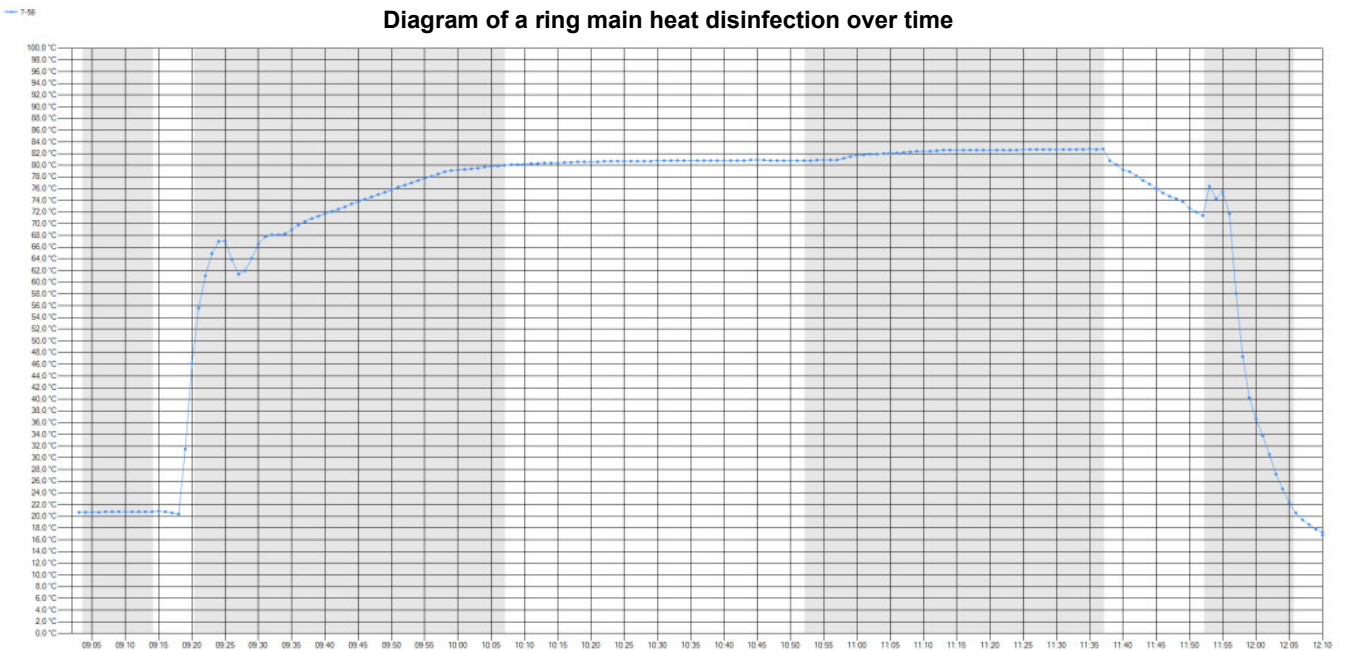

● Heating UF

HEAT DISINFECTION		🕒	Status	Back
Heating UF				
06 / 24 / 2021		FRESENIUS MEDICAL CARE	11 : 42 : 47	
Feed temperature	75.9 °C			
		Cancel		
Standby	Supply	Cleaning	System	

If a **AquaUF** is included in the configuration, it is brought to the target temperature before each ring main heat disinfection.

Rinsing ring main

HEAT DISINFECTION		🕒	Status	Back
Rinsing ring main				
06 / 24 / 2021		FRESENIUS MEDICAL CARE	11 : 57 : 46	
Feed temperature			75.9 °C	
Return temperature			32.7 °C	
Volume left			36 L	
		Cancel		
Standby	Supply	Cleaning	System	

During this part of the ring main heat disinfection program, the preset volume is discarded at the end of the ring main. This permits fast heating of the ring main.

Heating ring main

During this phase, the ring main and optional **AquaUF** are heated to the target temperature.

HEAT DISINFECTION		🕒	Status	Back
Heating ring main				
06 / 24 / 2021		FRESENIUS MEDICAL CARE	11 : 59 : 12	
Feed temperature			58.2 °C	
Return temperature			49.0 °C	
		Cancel		
Standby	Supply	Cleaning	System	

The **AquaHT** starts the ring main heat disinfection with this phase.

Ventilate

During this phase, an attempt is made to ventilate pump P5 if a drop in output has occurred due to an accumulation of air in pump P5. The duration of this phase depends on the quantity of trapped air, and the duration of ventilation.

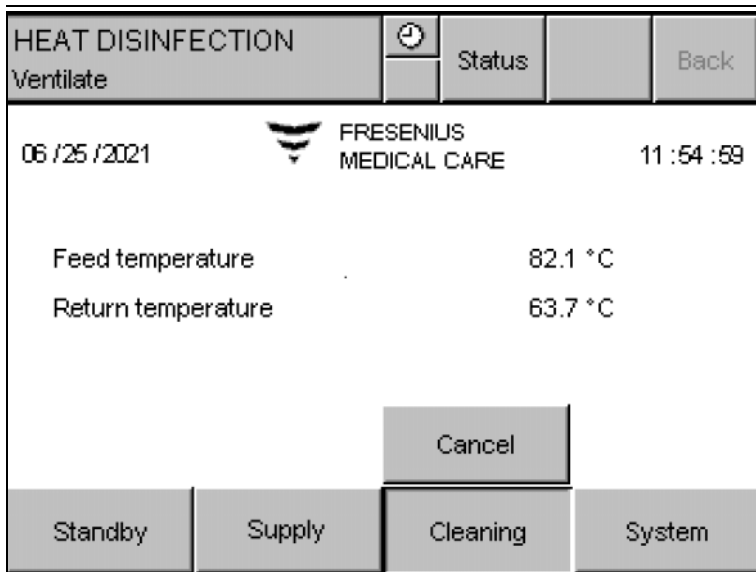

➤ The ventilate phase can be incorporated into the Heating ring main, Circulation or Consumption phases.

Circulation

During this phase, heating of the ring main continues in order to reach or maintain the target temperature.

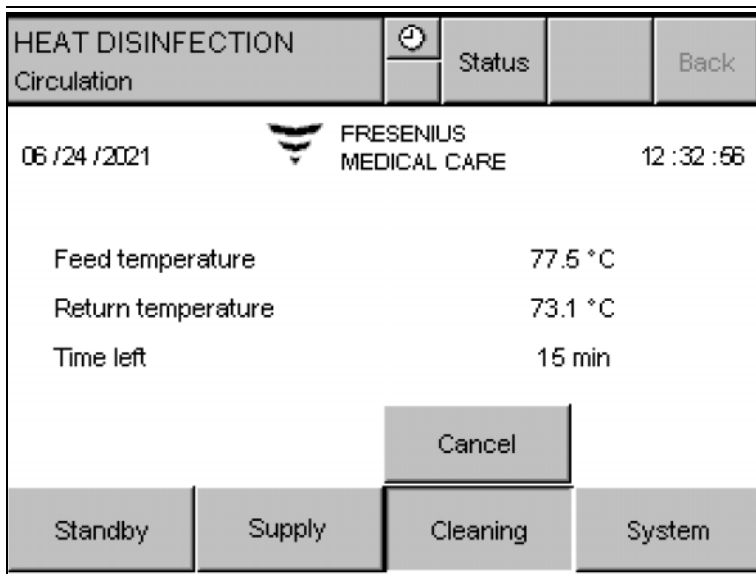

The circulation time is preset and can be prematurely stopped by consumption in the ring main (> 20 liters, e.g., by connected dialysis devices) with a simultaneous start of the consumption phase.

Consumption

During the consumption phase, the dialysis systems can be supplied with product water from the tank.

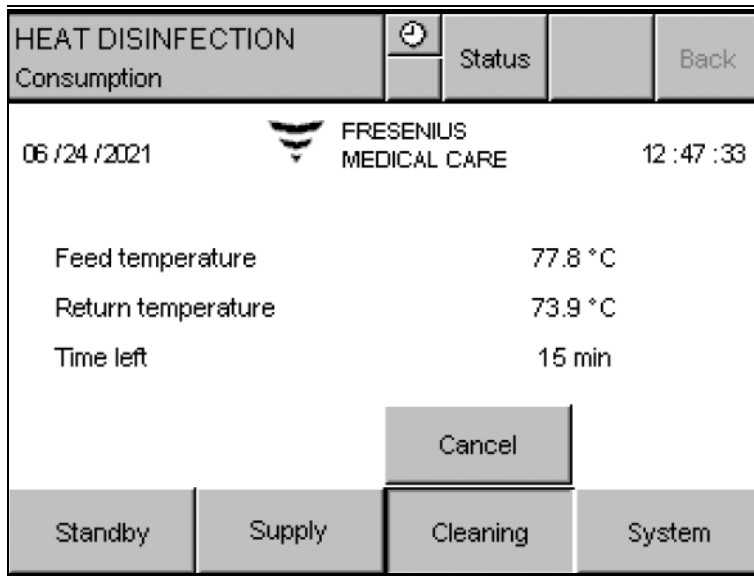

The dialysis devices can be supplied with hot product water from the tank during the consumption phase.

Cooling UF

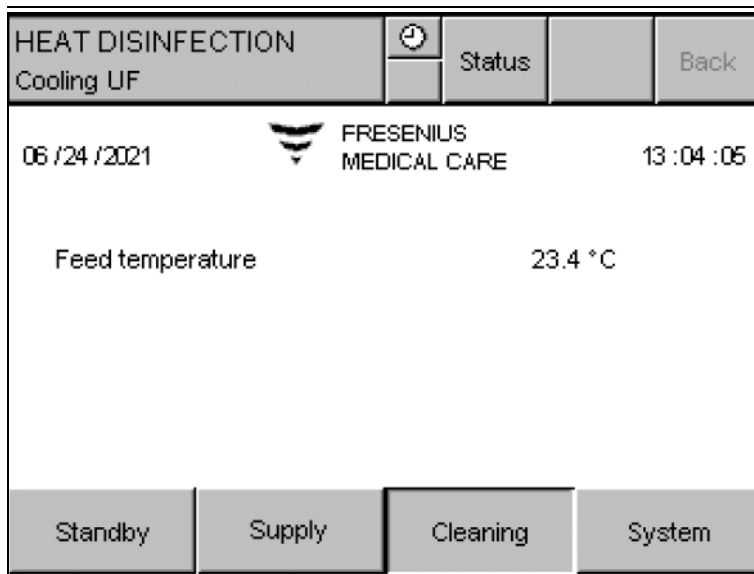

During this phase, the connected optional **AquaUF** is cyclically cooled for 15 minutes using cold dialysis water.

Cooling ring main

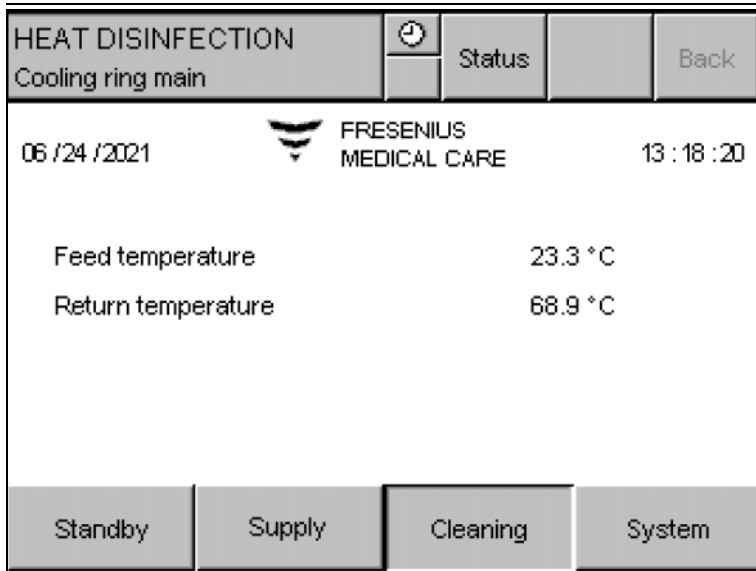

During the first part of this phase, the ring main is cooled to a temperature below 35 °C by discarding hot product water.

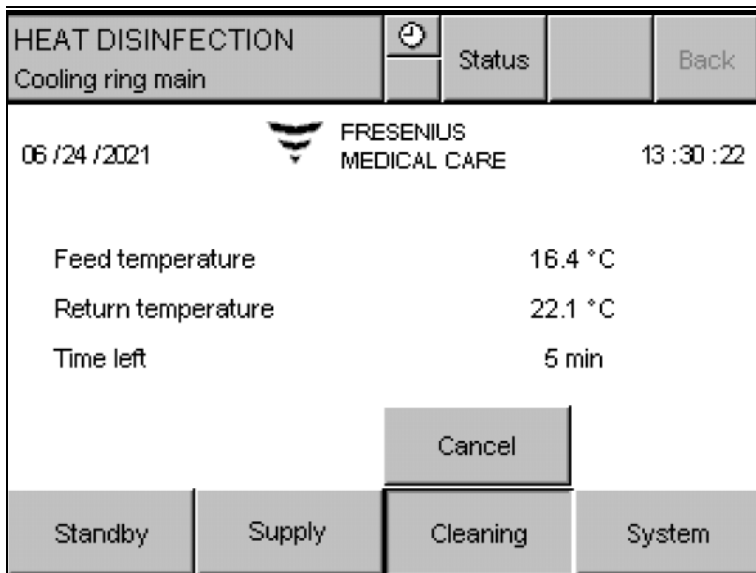

During the second part of this phase, rinsing of the ring main is started. Here, dialysis water is discarded on the **RingBase** for a preprogrammed duration. This part of the “Cooling ring main” phase can be stopped prematurely at any time using the **Cancel** button.

● **Module heat disinfection**

Example temperature graph during module heat disinfection:

The temperature graph shows the temperature over time during module heat disinfection:

If an **AquaA2** is connected, the membranes of the **AquaA2** will be included in the heat disinfection.

Heat disinfection graph for module heat disinfection

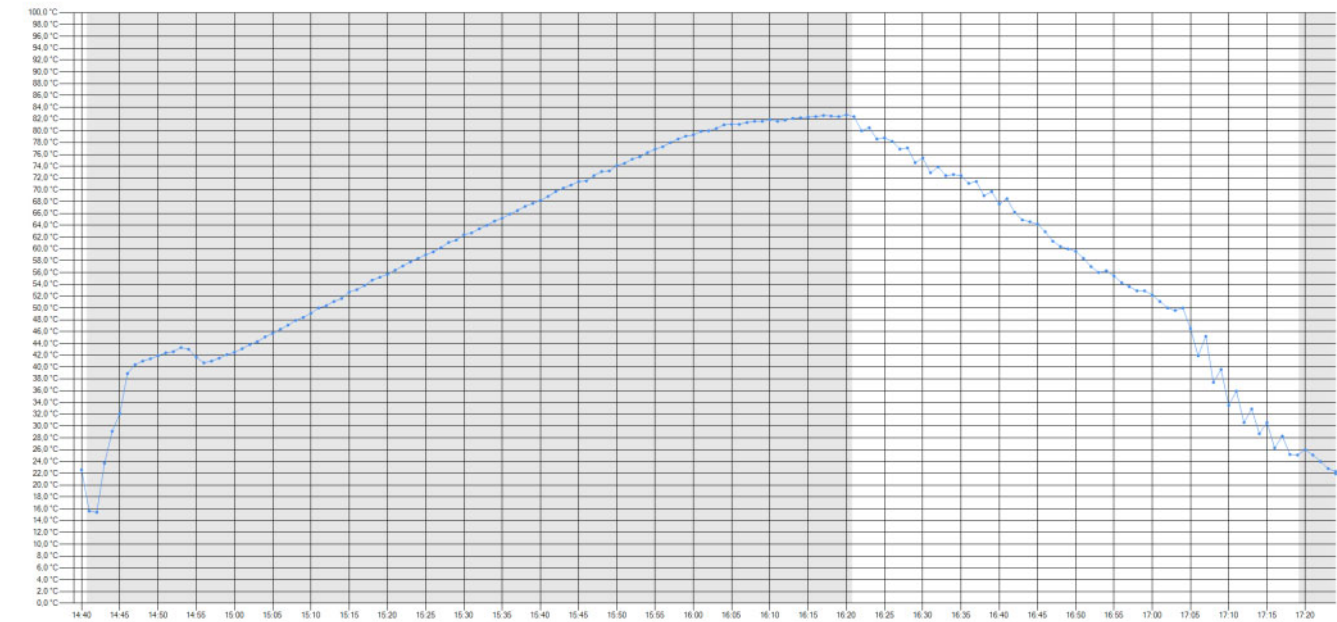

HEAT DISINFECTION		🕒	Status	Back
Heating tank				
06 / 25 / 2021		FRESENIUS MEDICAL CARE	11 : 02 : 53	
Preparation				
Valve position				
		Cancel		
Standby	Supply	Cleaning	System	

Module heat disinfection starts with checking the **AquaHT** tank volume and the tank temperature. Further information in the General heat disinfection phases paragraph (see chapter I on page 200).

Heating modules

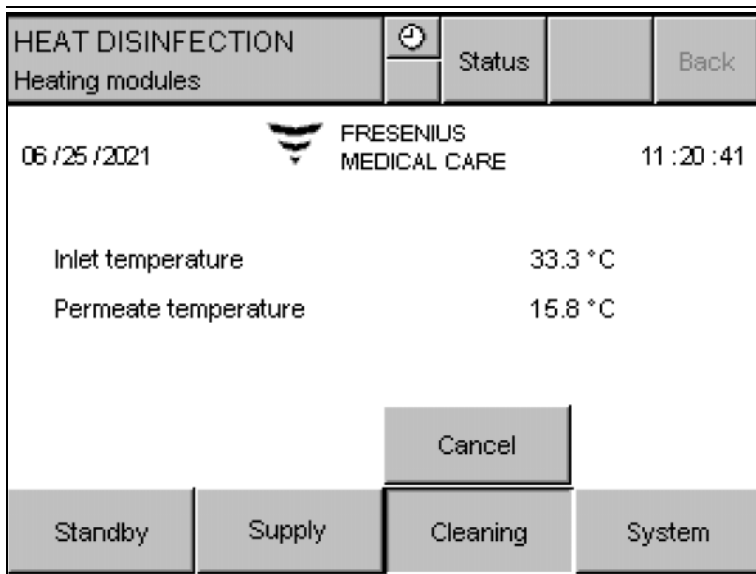

Heating of the modules is done in 2 phases.

- During the first phase, the **AquaA** break tank is cyclically filled with hot product water from the **AquaHT** tank. In this water exchange, the mixed water in the **AquaA** break tank is replaced with product water.
- The product water is then heated to the target temperature by the flow heaters.

Heating the membranes

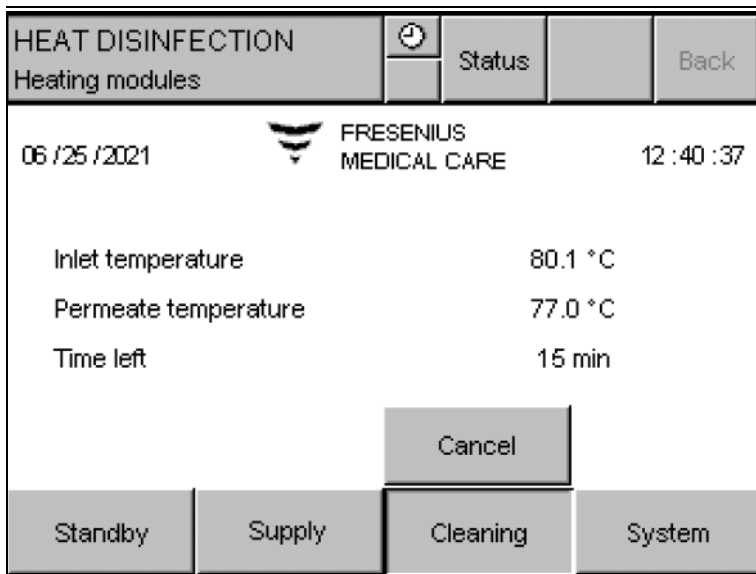

The heating of the membranes is shown in the following display.

The level of the **AquaA** break tank is first lowered and then replenished with hot product water from the **AquaHT**.

This process is repeated several times. To achieve a uniform heat distribution, the volume is circulated for 1 minute between each fill and drain cycle.

If the product temperature rises above 50 °C, the fill routine is stopped prematurely.

The flow heaters of the **AquaHT** then heat the **AquaA** product water to the desired membrane temperature.

After the desired membrane temperature has been reached, the temperature will be maintained for the programmed circulation time. During this heating phase, the remaining time is shown on the **AquaA** display.

Cooling modules

Cooling of the modules is done in 2 phases.

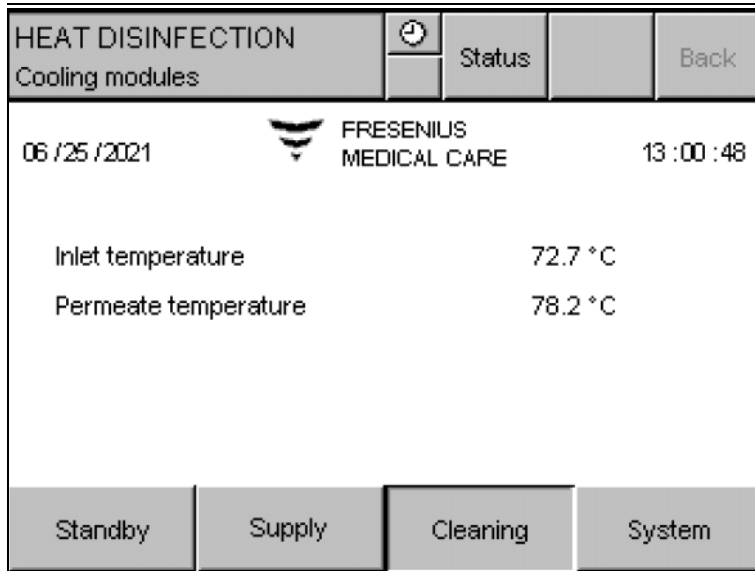

During the first phase, the **AquaA** break tank is cyclically filled with cold soft water.

In the second phase, cooling takes place through the continuous inflow of soft water with a simultaneous discarding of concentrate.

Rinsing modules

Rinsing of the modules is done as follows:

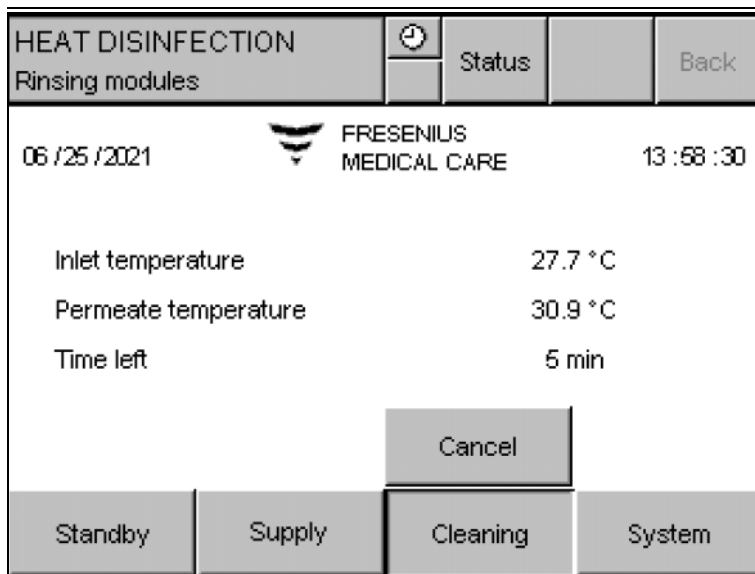

During this phase, all of the product water is discarded via the **RingBase** valve for a preprogrammed length of time.

After the programmed over-run time, the **AquaHT** tank is filled and heated.

14.2.5 SUPPLY mode–AquaHT

In **SUPPLY** mode, the flow through the **AquaHT** in the feed and return lines is via the bypass path.

During the **Start-Test**, two **AquaHT** flow paths are rinsed.

14.2.6 RINSE mode–AquaHT

In **RINSE** mode, the flow through the **AquaHT** in the feed and return lines is via the bypass path.

During the **Start-Test**, two **AquaHT** flow paths are rinsed.

14.2.7 DISINFECTION mode–AquaHT

During the entire disinfection program, the **AquaHT** is passive. However, the flow paths are rinsed by the **AquaHT** during the cycling rinse phases of the **AquaA**.

14.2.8 Cleaning, disinfection, preservation–AquaHT



Tip

For information on cleaning, disinfection, and preservation of the **AquaHT**, refer to the main chapters of the **AquaA**.

14.2.9 Functional description–AquaHT

● Heat disinfection of the reverse osmosis system with membranes

- Defined portions of hot product water are dispensed from the tank to the **AquaHT** in order to heat it.
- The product water and concentrate are then circulated in a closed circuit, and are heated to the target temperature according to a preset heating gradient.
- Once the target temperature has been reached, the temperature is maintained for the preset time.
- This phase is followed by the cool-down as defined by the preset cool-down gradient, by adding, circulating and draining soft water.

● Heat disinfection of the dialysis water ring main

- A programmable portion of hot product water is dispensed from the tank to the ring main; the corresponding volume is discarded at the **RingBase**. If an optional **AquaUF** is installed, it will first undergo defined heating in multiple rinses.
- The product water is then circulated in the ring main in a closed circuit by the circulation pump, and is heated to the target temperature according to a preset heating gradient.
- Once the target temperature has been reached, the temperature is maintained for the preset time.
- This phase is followed by the cool-down by adding, circulating and draining dialysis water. If an optional **AquaUF** is installed, it will first undergo defined cooling in multiple rinses.

● Interface heat disinfection

In the case of an interface heat disinfection, programming is performed on the dialysis device and the **AquaA**. The hot product water is then supplied from the ring main during the **AquaHT** consumption phase.



Note

The defaults for interface disinfection can be found in the Service Manual for interface heat disinfection.



Note

In case of considerable variations in the ambient temperature which influence the time required to heat the ring main, the consumption times may have to be adjusted to these conditions, e.g., to the time of the year.

The **AquaHT** control unit supplies the recorded ring main heating times.

The **AquaHT** is able to provide **380 liters**, less the initial ring main volume, within a short period of time.

14.2.10 Consumables, accessories, additional accessories–AquaHT



Note

Heat disinfection-type membranes are produced with a service life of 160 heat disinfection cycles.

If heat disinfection of the membrane takes place once a week, the membranes have an expected service life of 3 years.

For further information (see chapter 8.1 on page 142).

14.3 Ultrafilter AquaUF

The **AquaUF** ultrafiltration module is an option for the extension of the **AquaA** reverse osmosis system.

Part number	Options–description	Usage
(see chapter 8.3 on page 144)	Optional ultrafilter UF 2250; single filter	For higher dialysis water quality; up to 2250 L/h
(see chapter 8.3 on page 144)	Optional ultrafilter UF 4000; dual filter	For higher dialysis water quality; up to 4000 L/h

14.3.1 Functional description–AquaUF

The **AquaUF** ultrafiltration module is an extension module for the **AquaA** reverse osmosis system for higher dialysis water quality and increased safety regarding the microbial and endotoxin levels of the dialysis water.

The module does not expand the existing operating phases of the **AquaA**. Integration into the rinse concept is automatically activated after activation so that the ultrafilter will be rinsed during the start phases of **RINSE** and **SUPPLY**.

The dialysis water feed is connected to the ultrafiltration module via the piping. 2 ultrafiltration modules are used for a rated dialysis water output exceeding 2250 L/h.

Water constituents, such as bacteria and endotoxins, are held back in the ultrafilter module and removed through the open rinse valve during the next rinse process.

- **Intended use**

The **AquaUF** is intended to be used as a supplemental module to an **AquaA** and is installed directly upstream in front of the **RingBase**.

14.3.2 Design–AquaUF

- Complete device

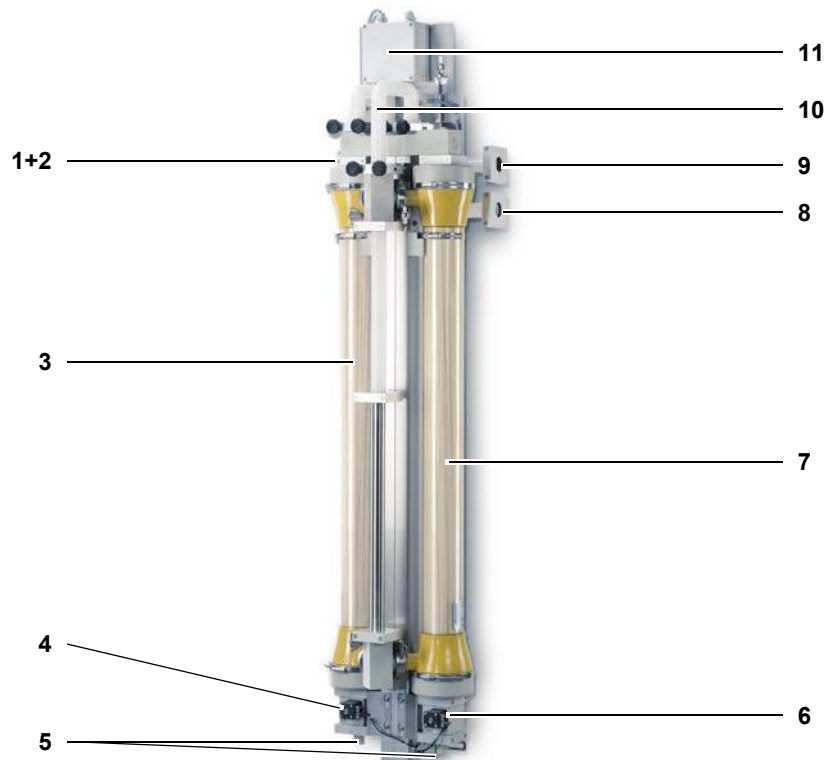

Legend:

- 1+2** Dialysis water feed from reverse osmosis system
Dialysis water return to reverse osmosis system
- 3** Ultrafilter 1
- 4** Rinse valve 1
- 5** Drain ports
- 6** Rinse valve 2
- 7** Ultrafilter 2 (rated dialysis water output > 2250 L/h)
- 8** Dialysis water return from ring main
- 9** Dialysis water feed to ring main
- 10** Emergency piping
- 11** **E-box**; valve connection

14.3.3 SUPPLY mode–AquaUF

Monitored dialysis water from the **AquaA** is passed through the **AquaUF**. In **SUPPLY** mode, the relevant rinse valve is cyclically opened for the configured time.

During **Start-Test**, the relevant rinse valve is briefly opened to permit rinsing. This is also done during the **SUPPLY** mode with the programmed rinse times and intervals.

14.3.4 RINSE mode–AquaUF

The device cleans itself with water by rinsing all line branches and by exchanging the ring main and device volume.

During **Start-Test**, the relevant rinse valve is briefly opened to permit rinsing. At the end of **RINSE** mode, the relevant rinse valve is opened for the configured time.

14.3.5 DISINFECTION mode–AquaUF

The **AquaA** integrates the **AquaUF** in the **DISINFECTION** mode.

While disinfection is in progress, the flow paths are rinsed by the **AquaUF** during the cyclic rinse phases of the **AquaA**.

14.3.6 HEAT DISINFECTION mode–AquaUF

If an optional **AquaHT** extension module is installed, the **AquaUF** will be included in the **AquaA** heat disinfection process.

14.3.7 Cleaning, disinfection, preservation–AquaUF



Tip

For information on cleaning, disinfection, and preservation of the **AquaUF**, refer to the main chapters of the **AquaA**.



Tip

Microbiological sampling upstream and downstream of the ultrafilter is recommended. This makes it possible to assess the service life and function of the ultrafilter.

14.4 TSDiag+–diagnostics tool

The **TSDiag+ tool** can be used for remote visualization of the **AquaA** display on a client (Windows notebook or PC with a connection to the network).

The **AquaA** can not be operated via this client.

The **TSDiag+** tool must be installed on the client.



Note

Use of the **TSDiag+** tool is only permitted within the in-house network of the dialysis unit!

14.4.1 Starting the TSDiag+

PC settings

The following settings must be configured on the PC before starting the **TSDiag+** client:

- The PC must have the default IP settings of the network.

Connection to the display

Connection to the display is established as follows:

- After starting the **TSDiag+** client, the screen for entering the network port and the IP address of the **DataCOM** will be displayed.

- The network port can be changed. For communication with the display of the **AquaA**, the network port must be changed to that of the **DataCOM**. When using a **DataCOM**, consult the IT documentation for the network port address.
- The IP address of the **DataCOM** must also be entered in this screen. For the **AquaA**, this is always the IP of the **DataCOM**.
- The entered data (IP address and network port) must always be confirmed with **OK**.
- After the entered IP address has been confirmed, the screen for entering the password will be displayed. This is only shown on the display if connection is successful.



- Enter the user name and the password. A distinction is made between two user levels. For further information on the user name and password, please contact your authorized technician.



- After confirming with **OK**, the connection to the display will be established.

The following message will be displayed:

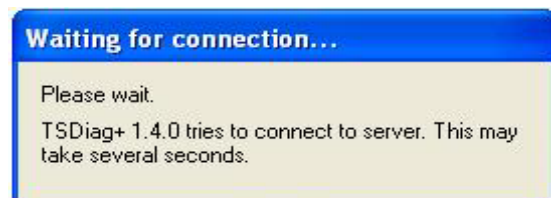

If no connection is established, the following message will be displayed:



After a successful connection, the device display will be shown on the computer.

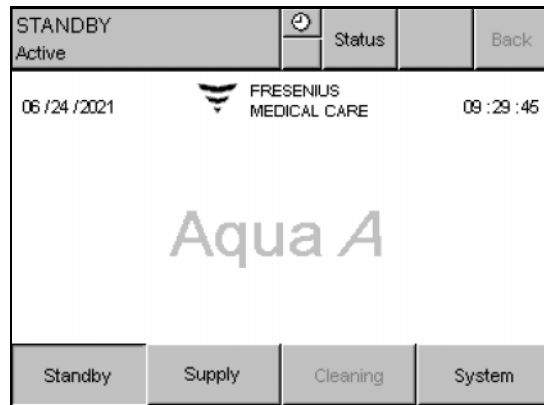

15 Appendix

15.1 AquaA Medical Device Register

15.1.1 Responsible organization and identification

The following page shows the master template for the address of the responsible organization and the identification.

AquaA	Address of the responsible organization & identification	
--------------	---	---

Address of the responsible organization
Name: _____
Address: _____
City: _____
Phone: _____
Site of installation _____

Internal medical consultant
Name, phone: _____
Name, phone: _____
Name, phone: _____
Name, phone: _____
Name, phone: _____

Identification
Device: AquaA
Type: Water treatment system, reverse osmosis system
Serial number: _____
Equipment code: _____
Options installed:
AquaA2; Serial number _____, Equipment code _____
AquaHT; Serial number _____, Equipment code _____
AquaUF; Serial number _____, Equipment code _____
Other additional equipment installed:
Visual LED indicator; Serial number _____
AquaDETECTOR; Serial number _____
DataCOM; Serial number _____
Manufacturer: Vivonic GmbH Germany / 63877 Sailauf

Tests and checks	
Type	Intervals
Technical Safety Check (TSC)	Every 24 months
_____	Every _____ months
_____	Every _____ months

Contracts regarding tests and checks:
Technical Safety Checks:
Company name: _____
Address: _____
Phone: _____

15.1.2 Contents of the AquaA Medical Device Register

The following page shows the contents of the Medical Device Register for the **AquaA**.

AquaA

Contents of the Medical Device Register



1	Instructions for Use
Monitoring	
2	System monitoring – Operational data acquisition reports
3	Microbiological and chemical monitoring – Results of the microbiological analysis – Results of the chemical analysis – Sample collection plans
4	Disinfection – Disinfection reports – Disinfection plans
5	Settings reports
6	Service reports, Training records, Malfunctions – Training records – Service reports and documentation of modifications to the system options – Reporting of incidences – Documentation of malfunctions and repeated, identical operating errors
7	Technical Safety Checks (TSC) and revalidation
Validation phase	
8	Installation qualification (IQ) – Installation report – Validation plan
9	Operational qualification (OQ) – Disinfection report OQ – Settings report OQ – Training record OQ – Sampling plan OQ – Disinfection plan OQ – Start-up report OQ
10	Performance qualification (PQ) – Operational data acquisition report PQ – Results of the microbiological analysis PQ – Results of the chemical analysis PQ

15.2 AquaA–Training Record

The following page shows the training record for the **AquaA**.

AquaA	Training Record	 FRESENIUS MEDICAL CARE
--------------	------------------------	---

Training location
Center, clinic: _____
Address: _____
Zip code, city: _____
Phone: _____
Fax: _____

Training period
From: _____
Until: _____

<input type="checkbox"/> Person(s) assigned by the responsible organization <input type="checkbox"/> Operator <input type="checkbox"/> Other Names: _____
--

Reverse osmosis system: <input checked="" type="checkbox"/> AquaA Serial no.: _____ Software version: _____ Operating hours: _____ Dialysis water capacity: <input type="checkbox"/> 900 L/h <input type="checkbox"/> 1000 L/h <input type="checkbox"/> 1800 L/h <input type="checkbox"/> 2000 L/h <input type="checkbox"/> 2700 L/h <input type="checkbox"/> 3000 L/h <input type="checkbox"/> 3600 L/h <input type="checkbox"/> 4000 L/h

Document	✓
Instructions for Use AquaA , version: _____	<input type="checkbox"/>
Training documentation	<input type="checkbox"/>
Operational data acquisition log (daily report)	<input type="checkbox"/>
Quick Reference Guide (QRG)	<input type="checkbox"/>

Comments:



Note

Observe index, important information, and all warnings in the Instructions for Use!

Training subjects			Filed in	✓
Basics				
A	Functional description (see chapter 7 on page 139)	<ul style="list-style-type: none"> – Principle of reverse osmosis – Physical background – Osmosis – Diffusion – Principle of the softener – Water hardness 	IFU	<input type="checkbox"/>
B	Installation requirements (see chapter 9.1 on page 145)	<ul style="list-style-type: none"> – The feed water must be of drinking water quality – Free fall of waste water 20–30 mm – Floor drain installed – Leakage sensor installed 	IFU	<input type="checkbox"/>
C	Intended purpose (see chapter 2.6 on page 18)	<ul style="list-style-type: none"> – Supply of dialysis devices – The total output of the dialysis devices may not exceed the capacity of the AquaA. 	IFU	<input type="checkbox"/>
Design				
A	AquaA front view (see chapter 3.1.2 on page 34)	<ul style="list-style-type: none"> – Main power switch – Display as touch screen control element – Emergency operation switch – Pumps – Visual indicator 	IFU	<input type="checkbox"/>
B	Rear view (see chapter 3.1.2 on page 34)	<ul style="list-style-type: none"> – Hydraulic connections – Electrical connection 	IFU	<input type="checkbox"/>
C	Interior front (see chapter 3.1.3 on page 35)	<ul style="list-style-type: none"> – E-box 1 – power electronics – E-box 2 – control electronics 	IFU	<input type="checkbox"/>
D	Side view (see chapter 3.1.3 on page 35)	<ul style="list-style-type: none"> – Break tank – RingBase with sampling – Concentrate restrictor DV3 (can be operated manually in case of a malfunction) 	IFU	<input type="checkbox"/>
E	Integrated leakage sensor	<ul style="list-style-type: none"> – Position and function 	IFU	<input type="checkbox"/>
F	AquaA2 front view (see chapter 14.1.3 on page 189)	<ul style="list-style-type: none"> – Main power switch – Pumps 	IFU	<input type="checkbox"/>
G	Emergency mode AquaA2 (see chapter 4.10.2 on page 72)	<ul style="list-style-type: none"> – Emergency operation switch – Emergency operation water supply path 	IFU	<input type="checkbox"/>
H	AquaHT front view (see chapter 14.2.3 on page 194)	<ul style="list-style-type: none"> – Tank 	IFU	<input type="checkbox"/>
I	Side view AquaHT (see chapter 14.2.3 on page 194)	<ul style="list-style-type: none"> – E-box 1 - power electronics – E-box 2 - control electronics – Pump 	IFU	<input type="checkbox"/>
J	Emergency mode AquaUF (see chapter 14.3.2 on page 213)	<ul style="list-style-type: none"> – Ultrafilter 	IFU	<input type="checkbox"/>
Controls and indicators				
A	Controls: Layout and function (see chapter 3.3.1 on page 39)	<ul style="list-style-type: none"> – Status bar with current operating mode and information menu: Switching programs, message and hourglass icons – Status menu – Display area – Operating modes and system buttons: Active and inactive command buttons – Selection of programs – System menu: Settings and service – Password protection 	IFU	<input type="checkbox"/>

Training subjects			Filed in	✓
Operating modes and functions				
A	Quick guide (see chapter 4.5 on page 48)	<ul style="list-style-type: none"> – Select program (STANDBY, SUPPLY, RINSE) – Press and hold the button for 3 seconds 	IFU	<input type="checkbox"/>
B	Operating programs (see chapter 4.4 on page 45), (see chapter 4.5 on page 48), (see chapter 4.6 on page 54), (see chapter 4.8 on page 60),	<ul style="list-style-type: none"> – STANDBY – SUPPLY – RINSE (Cleaning as well as the sub-operating modes Rinse AquaA and Rinse water pretreatment system) – EMERGENCY MODE 	IFU	<input type="checkbox"/>
C	Status menu (no password required) (see chapter 4.10.2 on page 72)	<ul style="list-style-type: none"> – Messages: <ul style="list-style-type: none"> Current messages Confirm messages – Report – Start, Stop: <ul style="list-style-type: none"> Switching program settings for Supply and Rinse Changing the autostop time once – System information: <ul style="list-style-type: none"> Configuration and system values – Operating data (current operating data) 	IFU	<input type="checkbox"/>
D	Emergency mode (see chapter 4.8 on page 60)	<ul style="list-style-type: none"> – No emergency supply with soft water – Dialysis water conductivity and temperature in the break tank are monitored – Activating the emergency mode: <ul style="list-style-type: none"> Turn the reverse osmosis system and any options off using the main power switch (OFF) Turn the AquaA emergency mode switch counter-clockwise or clockwise Turn the AquaA reverse osmosis system on using the main power switch (ON) The second pump can be switched on by pressing this switch—even if pump 1 fails to switch on. – Deactivating the emergency mode: <ul style="list-style-type: none"> Set the main power switch of the AquaA to the OFF position Set the emergency switch to its center position Return the main power switch of the AquaA reverse osmosis system and options to the ON position 	IFU	<input type="checkbox"/>
E	AquaA2 emergency mode (see chapter 4.8.4 on page 64)	<ul style="list-style-type: none"> – No emergency supply with soft water – Dialysis water conductivity is monitored – Activating the emergency mode: <ul style="list-style-type: none"> Turn the AquaA reverse osmosis system and options off using the main power switch (OFF) Change the water supply path to Emergency mode 2 Turn the AquaA2 emergency mode switch clockwise Turn the AquaA2 reverse osmosis system on using the main power switch (ON) The second pump can be switched on by pressing this switch—even if pump P1s fails to switch on – Deactivating the emergency mode: <ul style="list-style-type: none"> Turn the AquaA2 reverse osmosis system off using the main power switch (OFF) Change the water supply path to Standard operation 1 Set the emergency switch to its center position Return the main power switch of the AquaA, AquaA2 and options to the ON position. Before restoring dialysis operation, a disinfection (chemical or membrane heat disinfection) must be performed. 	IFU	<input type="checkbox"/>
Alarms				
A	Visual indicator (see chapter 3.3.1 on page 39)	<ul style="list-style-type: none"> – Red and flashing—an alarm or a malfunction has occurred and has not yet been confirmed – Yellow and flashing—a warning has occurred and has not yet been confirmed – Yellow—Disinfection or service in progress – Green—SUPPLY mode is active – Green and flashing—the system is in the process of switching to the SUPPLY mode 	IFU	<input type="checkbox"/>
B	Error messages (see chapter 5.4 on page 112)	<ul style="list-style-type: none"> – Are displayed directly if an alarm occurs – Refer to Chapter 5 "Alarms" in the Instructions for Use – Refer to Chapter 2 "Addresses" (Water Technology hotline) 	IFU	<input type="checkbox"/>

Training subjects			Filed in	✓
Documentation, maintenance				
A	Operational data acquisition (see chapter 4.10.5.1 on page 83)	<ul style="list-style-type: none"> – Date and time when the data was collected – Permeate conductivity CD-P – Permeate temperature T-P – Inlet conductivity CD-F – Inlet temperature T-F – Permeate pressure P-P – Concentrate pressure P-C – Feed flow FL-F – Diversion FL-C – Permeate consumption – Daily consumption – Efficiency (desired) – Efficiency (current) – Rejection rate 	IFU, ODR	<input type="checkbox"/>
B	Operational data acquisition AquaA2 (see chapter 4.10.5.2 on page 87) - Date and time when the data was collected	<ul style="list-style-type: none"> – Permeate conductivity CD-Ps – Permeate temperature T-Ps – Feed pressure P-Fs – Permeate pressure P-Ps – Concentrate pressure P-Cs – Feed flow FL-Fs – Diversion FL-Cs – Daily consumption – Rejection rate 	IFU, TD	<input type="checkbox"/>
C	Report of heat disinfections (see chapter 4.10.2.3 on page 74)	<ul style="list-style-type: none"> – Start of the heat disinfection program – Duration of the heat disinfection program – Type of heat disinfection program – Temp 1: Temperature 1 reached – Temp 2: Temperature 2 reached – Consumption: Dialysis water consumption from the AquaHT tank during heat disinfection. – A0: The A0 value achieved during heat disinfection 	IFU, TD	<input type="checkbox"/>
D	Maintenance (staff) (see chapter 11.2 on page 155)	<ul style="list-style-type: none"> – Refill softener salt – Check for leakage – Soft water sample – Replace the filter cartridges 	IFU	<input type="checkbox"/>
E	Report on the most recent activities (see chapter 4.10.2.4 on page 75)	<ul style="list-style-type: none"> – SUPPLY: Last start of SUPPLY mode – RINSE: Last start of RINSE mode. This includes rinsing of the AquaA as well as the RINSE-Water pretreatment. – CHEMICAL DISINFECTION: Last start of a chemical disinfection. – DECALCIFICATION: Last start of a decalcification. – ALKALINE CLEANING: Last start of an alkaline cleaning. – RING MAIN HEAT DISINFECTION: Last start of a ring main heat disinfection. This activity is only displayed when using an AquaHT. – MODULE HEAT DISINFECTION: Last start of a module heat disinfection. This activity is only displayed when using an AquaHT. 	IFU	<input type="checkbox"/>
Miscellaneous				
A	Various items (see chapter 15.7.3 on page 239), (see chapter 8.1 on page 142), (see chapter 15.1 on page 219), (see chapter 11.1 on page 155)	<ul style="list-style-type: none"> – Collection of microbiological samples – Ordering accessories (filter, salt) – Medical Device Register – Intervals for Technical Safety checks 	IFU, TD	<input type="checkbox"/>
IFU = Instructions for Use ODR = Operational data acquisition report TD = Training documentation				
Reference to the Instructions for Use: The device has been approved for use with the consumables, accessories and options listed in the Instructions for Use. Should the responsible organization wish to use consumables, accessories or options other than those listed in the Instructions for Use, the responsibility to ensure the correct function of the device lies exclusively with the responsible organization.				
Trainer				
Name		Date, signature		

Participant	
Name	Date, signature

15.3 Operational data acquisition

General notes



Note

- In accordance with ISO 23500-1 (or ISO 23500 respectively), we recommend daily monitoring of the operating data before hemodialysis treatment.
-
-

**Tip**

The current operating data of the **AquaA** can be listed using the **Status** button and the **Operating Data** selection button (see chapter 4.10.5.1 on page 83).

**Tip**

The **Shift** label provides the option to record the operating data multiple times per day. A separate operating data acquisition report is maintained for each **shift**.

15.3.1 Manual operational data acquisition report

The following page shows the master template for the operational data acquisition for the **AquaA**.

AquaA**Operational data acquisition
Daily report**

Serial number:
Liters:
Software:
Equipment code (EC):
Site of installation
Address:
ZIP code:
City:
Responsible technician:
Phone:

GENERAL NOTES

Monitoring of the operating parameters is indispensable to ensure safe and continuous operation of the reverse osmosis system. Meticulous recording of the data is also an absolute requirement for potential warranty claims. If values deviate, please inform the technical service so that they can take appropriate action before a malfunction occurs.

Distributor Fresenius Medical Care North America
 920 Winter Street
 Waltham, MA 02451-1457
 USA
 Customer Service group (800) 323-5188

Service International Vivonic GmbH
 Technical Customer Service / Support
 Kurfuerst-Eppstein-Ring 4
 D-63877 Sailauf
 Phone: +49 (0)6093 9713-23
 Fax: +49 (0)6093 9713-214

Local service **Fresenius USA, Inc.**
Technical Service Department
 4040 Nelson Avenue
 Concord, CA 94520
 fmcna.com
 Technical Service Group (800) 227 2572

15.3.2 Manual operational data acquisition report

The following pages show the operational data acquisition report for the **AquaA**.

Operational data acquisition, daily report AquaA	Year: _____ Calendar week: _____ Shift: <input type="checkbox"/> 1, <input type="checkbox"/> 2, <input type="checkbox"/> 3, <input type="checkbox"/> 4
---	--

Procedure								
Weekday	Mon	Tue	Wed	Thu	Fri	Sat	Sun	–
Time	_____	_____	_____	_____	_____	_____	_____	_____

	Entries (operator)							Unit	
AquaA									
Permeate conductivity CD-P	_____	_____	_____	_____	_____	_____	_____	µS/cm	
Permeate temperature T-P	_____	_____	_____	_____	_____	_____	_____	°C	
Inlet conductivity CD-F	_____	_____	_____	_____	_____	_____	_____	µS/cm	
Inlet temperature T-F	_____	_____	_____	_____	_____	_____	_____	°C	
Permeate pressure P-P	_____	_____	_____	_____	_____	_____	_____	bar	
Concentrate pressure P-C	_____	_____	_____	_____	_____	_____	_____	bar	
Feed flow FL-F	_____	_____	_____	_____	_____	_____	_____	L/min	
Diversion FL-C	_____	_____	_____	_____	_____	_____	_____	L/min	
Permeate consumption	_____	_____	_____	_____	_____	_____	_____	L/min	
Daily consumption	_____	_____	_____	_____	_____	_____	_____	liters	
Efficiency (desired)	_____	_____	_____	_____	_____	_____	_____	%	
Efficiency (current)	_____	_____	_____	_____	_____	_____	_____	%	
Rejection rate	_____	_____	_____	_____	_____	_____	_____	%	
AquaA2									
Permeate conductivity CD-Ps	_____	_____	_____	_____	_____	_____	_____	µS/cm	
Permeate temperature T-Ps	_____	_____	_____	_____	_____	_____	_____	°C	
Feed pressure P-Fs	_____	_____	_____	_____	_____	_____	_____	bar	
Permeate pressure P-Ps	_____	_____	_____	_____	_____	_____	_____	bar	
Concentrate pressure P-Cs	_____	_____	_____	_____	_____	_____	_____	bar	
Feed flow FL-Fs	_____	_____	_____	_____	_____	_____	_____	L/min	
Diversion FL-Cs	_____	_____	_____	_____	_____	_____	_____	L/min	
Rejection rate	_____	_____	_____	_____	_____	_____	_____	%	
AquaHT heat disinfection									
Ring main heat disinfection: performed without any problems?	<input type="checkbox"/> Yes <input type="checkbox"/> No	<input type="checkbox"/> Yes <input type="checkbox"/> No	<input type="checkbox"/> Yes <input type="checkbox"/> No	<input type="checkbox"/> Yes <input type="checkbox"/> No	<input type="checkbox"/> Yes <input type="checkbox"/> No	<input type="checkbox"/> Yes <input type="checkbox"/> No	<input type="checkbox"/> Yes <input type="checkbox"/> No	<input type="checkbox"/> Yes <input type="checkbox"/> No	–
Module heat disinfection: performed without any problems?	<input type="checkbox"/> Yes <input type="checkbox"/> No	<input type="checkbox"/> Yes <input type="checkbox"/> No	<input type="checkbox"/> Yes <input type="checkbox"/> No	<input type="checkbox"/> Yes <input type="checkbox"/> No	<input type="checkbox"/> Yes <input type="checkbox"/> No	<input type="checkbox"/> Yes <input type="checkbox"/> No	<input type="checkbox"/> Yes <input type="checkbox"/> No	<input type="checkbox"/> Yes <input type="checkbox"/> No	–
Initials									
	_____	_____	_____	_____	_____	_____	_____	_____	



Note

If the conductivity changes by more than 100 % compared with the previous average value for a significant length of time, it is essential to contact the responsible technician or the manufacturer.

15.4 Quality of dialysis water

The microbiological and chemical purity of the dialysis fluid prepared in the dialysis clinic is of critical importance for the quality of the patient's treatment. The quality of the dialysis water should comply with local regulations. If no local regulations apply, compliance with the applicable requirements of ISO 23500-3 (or ISO 13959 respectively) "Water for haemodialysis and related therapies" is necessary.

The quality of the dialysis water should be monitored regularly for listed chemical and microbiological contaminants. The monitoring schedule should be based on the results of the system validation. In an existing water treatment system operated under stable conditions, the chemical contaminants in the dialysis water should be monitored at least once every year. This excludes total chlorine which, if present in the feed water, should be monitored at the beginning of each treatment day.

Compliance with requirements for the chemical parameters according to ISO 23500-3 (or ISO 13959 respectively) may necessitate additional water pretreatment stages or a change in the yield on the device. The composition of the dialysis water must be checked as part of the performance qualification (PQ), and the water pretreatment and the settings on the device must be adjusted as needed.

● Microbiological quality of fluids for hemodialysis

Reference	Medium	Permissible maximum values	
		Total viable microbial count [CFU/ml]	Endotoxin concentration [EU/ml]
ISO 23500-3 (or ISO 13959 respectively) Water for haemodialysis and related therapies	Dialysis water	< 100 (AL* 50)	< 0.25 (AL* 0,125)
ISO 23500-5 (or ISO 11663 respectively) Quality of dialysis fluid for haemodialysis and related therapies	(Standard) dialysis fluid **	< 100 (AL* 50)	< 0.5 (AL* 0.25) (Ph.Eur: < 0.25)
*AL = Action Level. Starting at this concentration, steps must be taken to stop the trend from reaching higher, unacceptable values. This value is typically about 50 % of the maximum allowable level.			
**Tests for bacterial growth and endotoxins are not required if the dialysis device's fluid pathway is fitted with a bacteria-retentive and endotoxin-retentive filter that has an appropriate capacity, has been validated by the manufacturer, and is operated and monitored according to the manufacturer's instructions (e.g. DIASAFE plus).			

● **Chemical quality of dialysis water**

ISO 23500-3 (or ISO 13959 respectively)					
Contaminants with proven toxicity in dialysis	Maximum allowable level [mg/L]	Electrolytes	Maximum allowable level [mg/L]	Trace elements	Maximum allowable level [mg/L]
Aluminum	0.01	Calcium	2	Antimony	0.006
Lead	0.005	Potassium	8 (*2)	Arsenic	0.005
Fluoride	0.2	Magnesium	4 (*2)	Barium	0.1
Total chlorine	0.1	Sodium	70 (*50)	Beryllium	0.0004
Copper	0.1			Cadmium	0.001
Nitrate as (N)*	2			Chrome	0.014
Sulfate	100 (*50)			Mercury	0.0002 (*0.001)
Zinc	0.1			Selenium	0.09
				Silver	0.005
				Thallium	0.002

* Values according to the European Pharmacopoeia (Ph. Eur.); applicable regulations must be observed. Other deviations in Ph.Eur. are: nitrate: limit value = 2 mg/L nitrate in relation to the total nitrate molecule NO₃. Other contaminants listed only in the Ph.Eur. are: ammonium (NH₄): 0.2 mg/L; heavy metals (such as Pb): 0.1 mg/L; chlorides: 50 mg/L.

For continued compliance with quality standards, checks and disinfections of the dialysis water system must be performed regularly.

Recommended chemical surveillance

Annual inspection

The dialysis water should be checked for chemical contamination at least once a year.

Offline tests

If the feed water or pretreated water is chlorinated and offline tests are used, the total chlorine test should be performed downstream of the activated carbon filter at the beginning of each treatment day, before the first patient treatment. If chloramine is used at a concentration of 1 mg/L or more to disinfect the drinking water supply, the test should be repeated before the start of each patient session. If no patient sessions are scheduled, the test should be carried out approximately every 4 hours during operation.

15.5 Collecting a sample at the AquaA for microbiological analysis

The sampling port of the **AquaA** is the sampling valve, which can be opened by turning the valve.

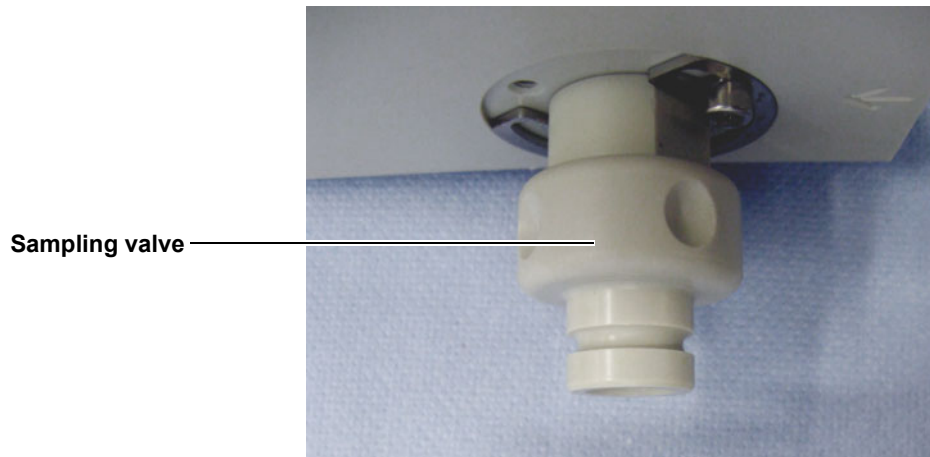

15.5.1 Preparation

- Have a cooled shipping box available.
- The reverse osmosis system must be operated in the **RINSE** or **SUPPLY** mode for at least 20 minutes before the sample is collected.
- While collecting the sample, the reverse osmosis system must be in the **RINSE** or **SUPPLY** program.
- Disconnect the dialysis water connection from the dialysis device. Perform the microbiological analysis according to the procedure described for collecting a sample at the dialysis water coupling.

15.5.2 Accessories, equipment

The following equipment is recommended by the manufacturer:

- Rubber gloves
- Alcohol-based hand disinfectant

For the chemical sampling, use the sample containers provided by the laboratory. The bag with adapter (part number: G03000836) can be used as dialysis water sampling equipment.

15.5.3 Collecting a sample on the AquaA





Illustration	Description
 <p data-bbox="177 645 248 674">Fig. 1</p>	<p data-bbox="703 293 1209 322">Fig. 1 - disinfecting the sampling valve:</p> <ul style="list-style-type: none"> <li data-bbox="703 338 1417 398">➤ Disinfect the sampling valve using an alcohol-based skin disinfectant (without lipid replenisher). <li data-bbox="703 416 1225 445">➤ Remove any contamination with a swab. <li data-bbox="703 463 1310 492">➤ Then repeat the disinfection procedure. (Fig. 1) <p data-bbox="703 562 1262 622">Caution: Observe the acting time of the disinfectant!</p>
 <p data-bbox="177 1055 280 1084">Fig. 2+3</p>	<p data-bbox="703 703 1262 732">Fig. 3 - connecting and locking the adapter:</p> <ul style="list-style-type: none"> <li data-bbox="703 748 1481 808">➤ Place the adapter of the sampling bag onto the sampling valve. (Fig. 2) <li data-bbox="703 826 1465 920">➤ Then lock the adapter. (Fig. 3) The multiway valve on the sampling set must be set so as to ensure that no fluid can flow.
 <p data-bbox="177 1469 248 1498">Fig. 4</p>	<p data-bbox="703 1113 1150 1142">Fig. 4 - opening the sampling valve</p> <ul style="list-style-type: none"> <li data-bbox="703 1158 1474 1187">➤ Turn the sampling valve counter-clockwise to open it. (Fig. 4)

Illustration	Description
 <p data-bbox="124 645 199 678">Fig. 5</p>	<p data-bbox="651 293 1086 327">Fig. 5 - rinsing the sampling valve</p> <ul style="list-style-type: none"> <li data-bbox="651 338 1150 371">➤ Turn the multiway valve 90° clockwise. <li data-bbox="651 383 1425 450">➤ Rinse the sampling valve for approx. 60 seconds via the rinse tubing. (Fig. 5)
 <p data-bbox="124 1055 199 1088">Fig. 6</p>	<p data-bbox="651 703 922 736">Fig. 6 - filling the bag</p> <ul style="list-style-type: none"> <li data-bbox="651 748 1425 815">➤ Then turn the multiway valve again 90° clockwise to fill the bag. (Fig. 6) <li data-bbox="651 826 1398 927">➤ Caution: Make sure to return the multiway valve in time to its original position (Fig. 4) to prevent bursting of the bag!
	<p data-bbox="651 1113 1114 1146">Completing the sampling procedure</p> <ul style="list-style-type: none"> <li data-bbox="651 1158 1430 1191">➤ The sampling valve is now closed again by turning it clockwise. <li data-bbox="651 1202 1386 1270">➤ Clamp of the disposable parts after the multiway valve and immediately close the bag with the enclosed plug. <li data-bbox="651 1281 1249 1314">➤ Gently squeeze the bag to check for any leaks. <li data-bbox="651 1326 1358 1393">➤ Affix the completed label on the bag and place it into the prepared transport box.



Note

Local policy and procedures may supersede the manufacturers sampling methods.

15.6 Collecting a sample for microbiological analysis

The sampling port is the dialysis water coupling.

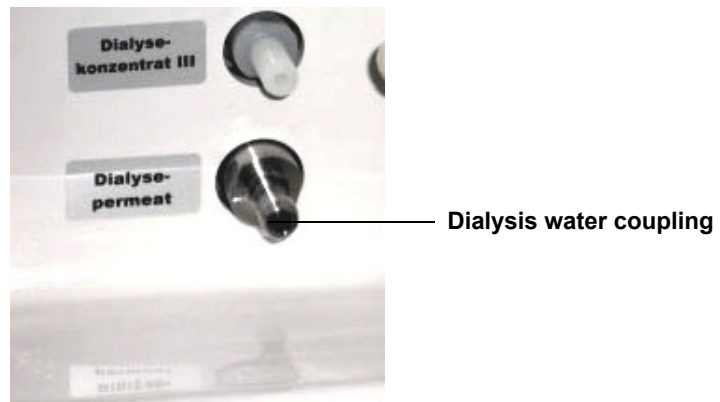

15.6.1 Preparation

- Have a cooled shipping box available.
- The reverse osmosis system must be operated in the **RINSE** or **SUPPLY** mode for at least 20 minutes before the sample is collected.
- While collecting the sample, the reverse osmosis system must be in the **RINSE** or **SUPPLY** program.
- Disconnect the dialysis water connection from the dialysis device, and perform the procedure described for collecting a sample at the dialysis water coupling.

15.6.2 Accessories, equipment

The following equipment is recommended by the manufacturer:

- Rubber gloves
- Alcohol-based hand disinfectant

For the chemical sampling, use the sample containers provided by the laboratory. The bag with adapter (part number: G03000832) can be used as dialysis water sampling equipment.

15.6.3 Collecting a sample on the MSC

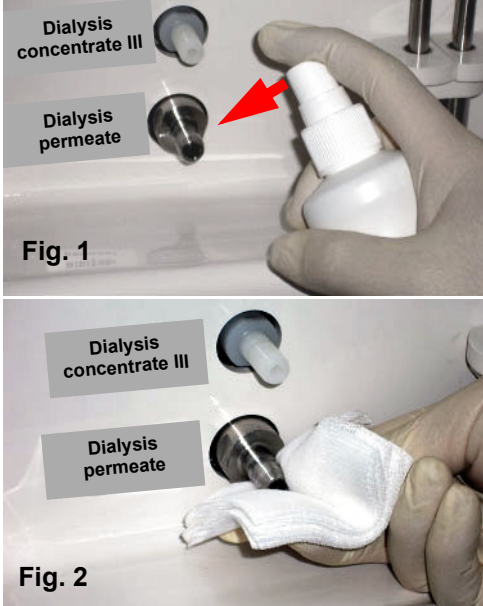
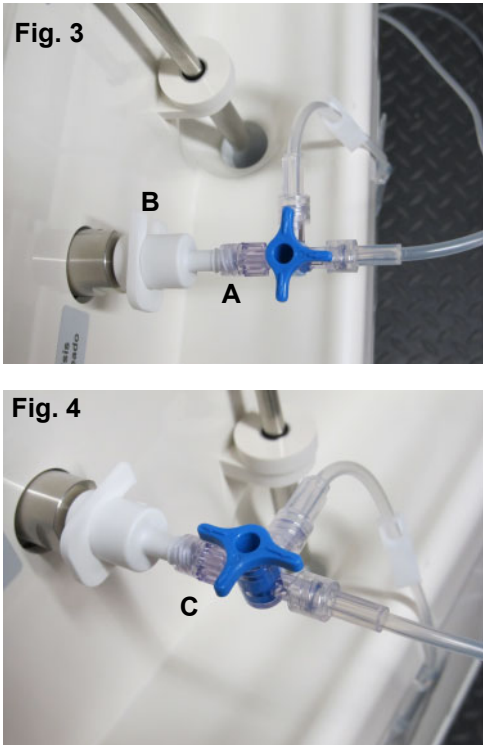
Illustration	Description
 <p>Fig. 1</p> <p>Fig. 2</p>	<p>Fig. 1 and 2 - disinfecting the permeate coupling:</p> <ul style="list-style-type: none"> ➤ Use an alcohol-based skin disinfectant (e.g., SEPTODERM®) to disinfect the permeate coupling (Fig. 1). <p>Caution: Observe the acting time of the disinfectant!</p> <ul style="list-style-type: none"> ➤ Remove any contamination with a swab (Fig. 2). ➤ Then repeat the disinfection process (Fig. 1).
 <p>Fig. 3</p> <p>Fig. 4</p>	<p>Fig. 3 and 4 - collecting the sample:</p> <ul style="list-style-type: none"> ➤ Set the multiway valve on the sampling set (A) so as to ensure that no fluid can flow (Fig. 3). ➤ Place the adapter of the sampling bag on the coupling and lock it (B) (Fig. 3). ➤ Then turn the multiway valve 90° clockwise (C) and "rinse" the coupling for approx. 60 seconds via the rinse tubing (Fig. 3). ➤ Then turn the multiway valve again 90° clockwise to fill the bag (Fig. 4). <p>- Danger! Make sure to return the multiway valve in time to its original position (A) (Fig. 3) to prevent bursting of the bag!</p> <ul style="list-style-type: none"> ➤ Disconnect the disposable parts after the multiway valve and immediately close the bag with the enclosed plug. ➤ Gently squeeze the bag to check for any leaks. <p>- Affix a completed label on the bag and place it immediately into the prepared shipping box.</p>

15.7 Collecting a sample for chemical analysis

15.7.1 Preparation

Dialysis water sampling is only possible if the reverse osmosis system is in the **SUPPLY** mode, or if it is producing dialysis water during a manual rinse program in the **RINSE** mode.

Before collecting the sample, the reverse osmosis system must have been in operation for at least 20 minutes. If the device is not in the **SUPPLY** mode, the manual rinse program must be started.

The sample is collected in the **SUPPLY** or **RINSE** mode.

15.7.2 Accessories, equipment

The following equipment is recommended by the manufacturer:

- Rubber gloves

For the chemical sampling, use the sample containers provided by the laboratory. The bag with adapter (part number: G03000832) can be used as dialysis water sampling equipment.

15.7.3 Collecting a sample for chemical analysis

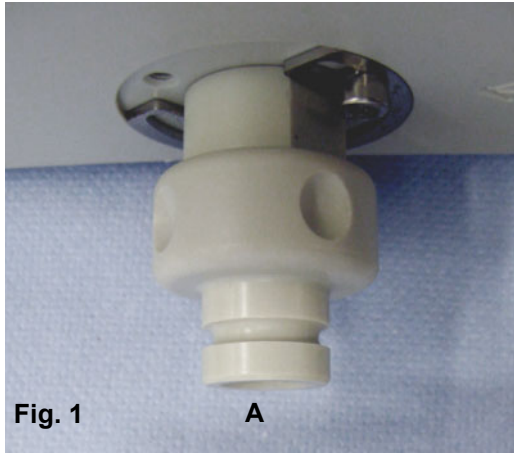
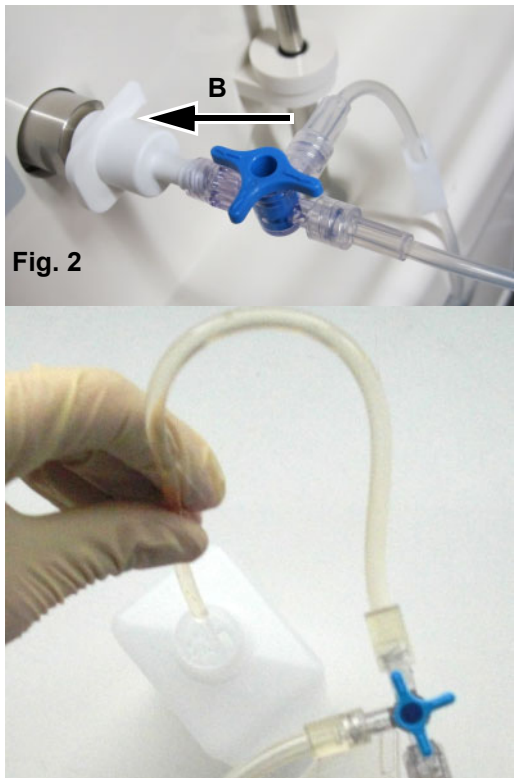
Illustration	Description
 <p>Fig. 1 A</p>	<ul style="list-style-type: none"> ➤ The permeate must be collected while the system is in operation (during dialysis) or after extensive rinsing of the system (see above). Before collecting the sample, rinse the sampling valve (A or B) (approx. 2-10 L). <p>Caution: To avoid contamination of the sample by dirty sample containers, use only the containers supplied by the laboratory!</p> <ul style="list-style-type: none"> ➤ When collecting the sample, do not open the sample containers until directly before collecting the sample and make sure to close the containers immediately after taking the sample to prevent contamination. ➤ The sample containers must be filled up to the top. ➤ When collecting a sample the valve must first be sufficiently rinsed (approx. 5 L). Then the sample containers must be filled from the free flowing jet of water.
 <p>Fig. 2</p>	<ul style="list-style-type: none"> ➤ When collecting the sample on the media supply column attach the bag / adapter to the coupling and fix it in place with the latch (Fig. 2 – B). ➤ Then thoroughly rinse the coupling (approx. 2 L) via the rinse tube. ➤ Fill the sample container via the rinse tube. <p>Caution: When collecting a sample at the media supply column coupling, do not use the bag (with adapter) as a sample container. Use the bottles supplied by the laboratory as sample containers!</p>